

MAS6253**Piezo Driver with Synchronous Boost DC/DC Converter**

- Up to 40Vpp Output
- 8 Step Output Voltage Control via I2C Bus
- Wide Supply Voltage Range 1.9V...5.5V
- Soft-Start
- Coin Cell Battery Optimized Regulation
- Short Circuit Protection
- High Efficiency
- External Schottky Diode Not Needed
- Very Low Leakage Current

DESCRIPTION

MAS6253 is a piezo driver device that can drive piezo sounders up to 40Vpp using wide range of supply voltage from 1.9V to 5.5V. An internal high efficiency DC/DC boost converter with programmable output voltage generates up to 20V supply voltage for piezo driver stage. The output stage is capable of driving even large sized piezo sounders with load capacitance up to 47nF. The two piezo driver outputs (VOP, VON) allow driving piezo sounder in either single-ended or differential bridge-tied load (BTL) configuration.

The MAS6253 can be operated just via single DIN pin when having output voltage configuration fixed. Two different output control modes are supported. In pin control mode there are four different output voltage options to choose from just by logic state of SCL and SDA pins. In I2C bus control mode there are eight different output voltage options available. Additionally, in both control modes there are two different output voltage regulation modes supported. The constant output voltage regulation offers constant output voltage and sound pressure level (SPL) independent of input voltage. Whereas in the constant voltage boost ratio regulation the ratio between input and output voltage is kept constant. This is an advantageous regulation mode especially in current consumption critical coin battery cell applications since current consumption is automatically reduced along with battery voltage dropping and which could be due to heavy loading or battery depletion.

Since the output voltage control influences not only sound pressure level (SPL) but also current consumption it can be a useful feature for controlling power consumption in energy critical battery applications.

To drive piezo sounder, it is only needed to apply desired frequency signal to the DIN pin. The pulsed signal at DIN pin turns on the DC/DC converter which features soft-start to keep inrush current at low level. The piezo driver outputs are activated when output voltage has risen to selected level. The VOP piezo driver output provides non-inverted and the VON inverted output relative to the DIN signal. By having the DIN pin kept low for at least 20ms sets the device back to shutdown state during which it draws only a minimum amount of current typ 20nA.

The on-chip synchronous type boost DC/DC converter makes external Schottky diode unnecessary thus requiring only a minimum number of external components. Together with integrated output voltage control circuitry the MAS6253 is an ideal piezo sounder drive solution offering high sound pressure level at a low cost and in a small size with added controllability of both sound volume and power consumption levels.

The MAS6253 is available in small 2x2x0.5 mm DFN-10 package.

FEATURES

- Up to 40Vpp even to 47nF piezo sounder
- High Efficiency Boost DC/DC Converter
- Wide Supply Voltage Range 1.9V...5.5V
- Low Inrush Current by Soft-Start Feature
- External Schottky Diode Not Needed
- Small Inductor
- Very Low Leakage Current typ 20nA
- Short Circuit Protection
- Thermal Shutdown

APPLICATIONS

- Portable Tracker Devices
- Sport Watches
- Medical Devices
- Smoke Alarms
- White Goods
- Alarm Clocks
- Battery Powered Devices with Sound Feature

ABSOLUTE MAXIMUM RATINGS

All voltages with respect to ground.

Parameter	Symbol	Conditions	Min	Max	Unit
Supply Voltage	V_{IN}		-0.3	6	V
High Voltage Pins	V_{OUT}		SW - 0.3	24	V
	SW		- 0.3	24	
	VOP, VON		-0.3	$V_{OUT} + 0.3$	
Voltage Range for Input Pins	DIN, SCL, SDA		-0.3	$V_{IN} + 0.3$	V
Storage Temperature			-40	+150	°C
Junction Temperature			-40	+180	°C
ESD Rating	V_{HBM}	Human Body Mode ⁽¹⁾	±1000		V
	V_{CDM}	Charged Device Model ⁽²⁾	±500		V

Note: Stresses beyond the values listed may cause a permanent damage to the device. The device may not operate under these conditions, but it will not be destroyed.

Note 1: JEDEC document JEP155 states that 500V HBM allows safe manufacturing with a standard ESD control process.

Note 2: JEDEC document JEP157 states that 250V CDM allows safe manufacturing with a standard ESD control process.

RECOMMENDED OPERATING CONDITIONS

All voltages with respect to ground.

Parameter	Symbol	Conditions	Min	Typ	Max	Unit
Operating Supply Voltage	V_{IN}		1.9	3.0	5.5	V
Operating Ambient Temperature	T_A		-40	+27	+105	°C
Operating Junction Temperature	T_J		-40		+125	°C
Inductor Specification	$L^{(3)}$	Li-ion/LiPo battery CR2032 coin cell	-30%	1 2.2	30%	μH
	I_{PEAK}	L=1μH (Li-ion/LiPo battery) L=2.2μH (CR2032 coin cell)		800 370	1600 750	mA
	R_{DC}	L=1μH (Li-ion/LiPo battery) L=2.2μH (CR2032 coin cell)		0.1 0.2	0.25 0.5	Ω
Piezo Input Signal Frequency	F_{DIN}	$V_{IN} = 3.7V$, $V_{OUT} = 20V$ L=1μH, $C_{LOAD} = 33$ nF	0.2		15	kHz
		$V_{IN} = 2.7V$, $V_{OUT} = 15V$ L=2.2μH, $C_{LOAD} = 22$ nF	0.2		10	kHz

Note 3: Shielded inductor recommended for low EMI. See "Inductor (L) selection" on page 6 for further information.

ELECTRICAL CHARACTERISTICS
 $T_A = -40^{\circ}\text{C}$ to $+105^{\circ}\text{C}$, typical values at $T_A = 27^{\circ}\text{C}$, $V_{IN} = 3\text{V}$, $L = 1\ \mu\text{H}$, $C_{IN} = 10\ \mu\text{F}$, $C_{OUT} = 1\ \mu\text{F}$, $C_{LOAD} = 22\ \text{nF}$, $DIN = 3.2\ \text{kHz}$; unless otherwise specified

Parameter	Symbol	Conditions	Min	Typ	Max	Unit
Thermal Shutdown Temperature	T_{TSD}	Rising temperature (device off) Falling temperature (device on)		+150 +135		$^{\circ}\text{C}$
Undervoltage-Lockout Threshold Levels	$UVLO_{RISE}$ $UVLO_{FALL}$	Turn on level at V_{IN} rising Turn off level at V_{IN} falling	1.4 1.3	1.5 1.4	1.6 1.5	V
Output Over Voltage Protection Level ⁽⁴⁾	OVP		-5%	20	+5%	V
DC/DC Converter Output Voltage in Constant Output Voltage Regulation	V_{OUT}	$L=1\ \mu\text{H}$, $V_{IN}=3.7\text{V}$, $I_{LOAD}=10\text{mA}$ $V_{OUT}=20\text{V}$ (0dB reference) $V_{OUT}=17.5\text{V}$ (-1.2dB) $V_{OUT}=15\text{V}$ (-2.5dB) $V_{OUT}=12.9\text{V}$ (-3.8dB) $V_{OUT}=11.1\text{V}$ (-5.1dB) $V_{OUT}=9.5\text{V}$ (-6.5dB) $V_{OUT}=8.1\text{V}$ (-7.9dB) $V_{OUT}=7\text{V}$ (-9.1dB)	-5%	20 17.5 15 12.9 11.1 9.5 8.1 7	+5%	V
DC/DC Converter Output Voltage in Constant Voltage Boost Ratio Regulation	V_{OUT}	$L=2.2\ \mu\text{H}$, $V_{IN}=2.7\text{V}$, $I_{LOAD}=6\text{mA}$ $V_{OUT}=20\text{V}$ (0dB reference) $V_{OUT}=17.5\text{V}$ (-1.2dB) $V_{OUT}=15\text{V}$ (-2.5dB) $V_{OUT}=12.9\text{V}$ (-3.8dB) $V_{OUT}=11.1\text{V}$ (-5.1dB) $V_{OUT}=9.5\text{V}$ (-6.5dB) $V_{OUT}=8.1\text{V}$ (-7.9dB) $V_{OUT}=7\text{V}$ (-9.1dB)	-5%	20 17.5 15 12.9 11.1 9.5 8.1 7	+5%	V
Piezo Driver Output Voltage	VOP, VON	VOP (single-ended): $C_{LOAD}=47\text{nF}$ VOP-VON: $C_{LOAD}=47\text{nF}$		V_{OUT} $2*V_{OUT}$		Vpp
Shutdown Current ⁽⁵⁾	I_{SD}	DIN=LOW		0.02	0.5	μA
Quiescent Current ⁽⁶⁾	I_Q	DIN=HIGH, no load, $V_{OUT}=20\text{V}$ $V_{IN}=3.0\text{V}$		2.1		mA
DC/DC Converter Soft Start Current	I_{IN_SS}	$V_{IN}=3.0\text{V}$ $L=1\ \mu\text{H}$ (Li-ion battery application) $L=2.2\ \mu\text{H}$ (CR2032 application)		20 9.3	40 18.6	mA
Current Consumption at Shorted Piezo Driver Outputs	I_{IN_SC}	VOP=VON or VOP=GND or VON=GND $V_{IN}=3.7\text{V}$ (Li-ion/LiPo), $L=1\ \mu\text{H}$ $V_{IN}=3.0\text{V}$ (CR2032), $L=2.2\ \mu\text{H}$		20 9.3	40 18.6	mA

Note 4: In constant voltage boost ratio regulation mode, the output voltage is limited to over voltage protection (OVP) level if the chosen voltage boost ratio and input voltage would otherwise lead to output voltage higher than the OVP voltage

Note 5: DIN has been low at least 20 ms.

Note 6: Current consumption when boost converter is active but outputs are not loaded

ELECTRICAL CHARACTERISTICS
 $T_A = -40^{\circ}\text{C}$ to $+105^{\circ}\text{C}$, typical values at $T_A = 27^{\circ}\text{C}$, $V_{IN} = 3\text{V}$, $L = 1\ \mu\text{H}$, $C_{IN} = 10\ \mu\text{F}$, $C_{OUT} = 1\ \mu\text{F}$, $C_{LOAD} = 22\ \text{nF}$, $DIN = 3.2\ \text{kHz}$; unless otherwise specified

Parameter	Symbol	Conditions	Min	Typ	Max	Unit
Average Current Consumption in Constant Output Voltage Regulation	I_{IN_COV}	$V_{IN} = 3.7\text{V}$, $V_{OUT} = 20\text{V}$, $L = 1\ \mu\text{H}$ VOP (single-ended): $C_{LOAD} = 22\text{nF}$ VOP-VON: $C_{LOAD} = 22\text{nF}$		23 80		mA
		$V_{IN} = 2.8\text{V}$, $V_{OUT} = 20\text{V}$, $L = 1\ \mu\text{H}$ VOP (single-ended): $C_{LOAD} = 22\text{nF}$ VOP-VON: $C_{LOAD} = 22\text{nF}$		69 210		mA
Average Current Consumption in Constant Boost Ratio Regulation	I_{IN_CBR}	$V_{IN} = 2.7\text{V}$, $V_{OUT} = 15\text{V}(V_{IN}/2.7\text{V})$, $L = 2.2\ \mu\text{H}$ VOP (single-ended): $C_{LOAD} = 22\text{nF}$ VOP-VON: $C_{LOAD} = 22\text{nF}$		14 46		mA
		$V_{IN} = 2\text{V}$, $V_{OUT} = 15\text{V}(V_{IN}/2.7\text{V})$, $L = 2.2\ \mu\text{H}$ VOP (single-ended): $C_{LOAD} = 22\text{nF}$ VOP-VON: $C_{LOAD} = 22\text{nF}$		13 41		mA
Power-on-Reset (POR) Time ⁽⁷⁾	t_{POR}		2			ms
DC/DC Converter Soft-Start Time	$t_{START-UP}$	$L = 1\ \mu\text{H}$ (Li-ion battery application) $V_{IN} = 3.7\text{V}$, $V_{OUT} = 20\text{V}$ $C_{OUT} = 470\text{nF}$ $C_{OUT} = 1\ \mu\text{F}$		2 4.3		ms
		$L = 2.2\ \mu\text{H}$ (CR2032 battery application) $V_{IN} = 3\text{V}$, $V_{OUT} = 15\text{V}$ $C_{OUT} = 470\text{nF}$ $C_{OUT} = 1\ \mu\text{F}$		4.4 9.5		ms
Shutdown Delay	t_{OFF}	Time before device off mode after DIN has gone to LOW	5	10	20	ms
Boost DC/DC Converter Switch ON-Resistance	$R_{DS(ON)_LS}$	Low side switch $V_{IN} = 3\text{V}$, $V_{OUT} = 15\text{V}$		0.5		Ω
	$R_{DS(ON)_HS}$	High side switch $V_{IN} = 3\text{V}$, $V_{OUT} = 15\text{V}$		1		
I2C Bus Clock Frequency	f_{SCL}				400	kHz
Control Input Threshold ⁽⁸⁾	V_{IH}	DIN, SCL, SDA, RM pins	0.9			V
	V_{IL}	DIN, SCL, SDA, RM pins			0.4	V
Control Input Current ⁽⁹⁾	I_{IH}	DIN, RM, SCL, SDA = 3V			0.2	μA
	I_{IL}	DIN, RM, SCL, SDA = 0V			-0.2	μA

Note 7: To guarantee proper power-on-reset (POR) operation the supply voltage must rise within maximum 2ms.

 Note 8: Control inputs and serial bus can be driven even from down to 1.2V supply voltage controller due to low 0.9V V_{IH} min threshold.

 Note 9: DIN pin has active pull-down by 400k Ω which is disabled to save current when inputs are pulled high ($\geq 0.9\text{V}$).

BLOCK AND APPLICATION DIAGRAMS

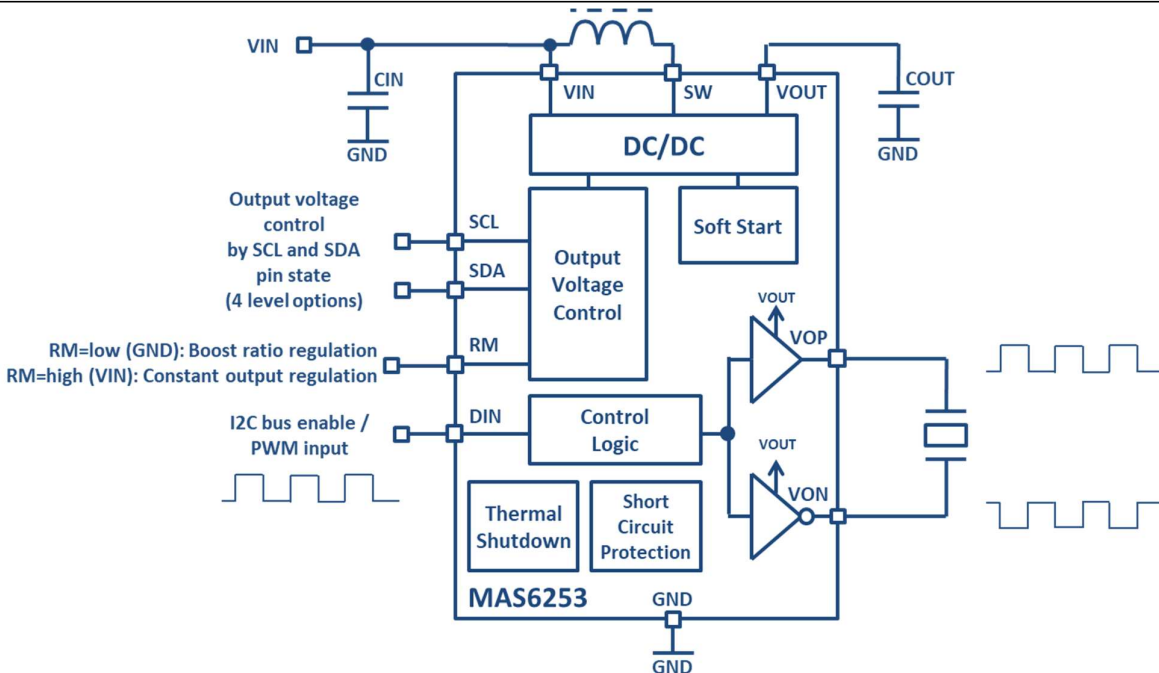

Figure 1. SCL and SDA pin state controlled output voltage level. RM pin state selects output regulation mode.

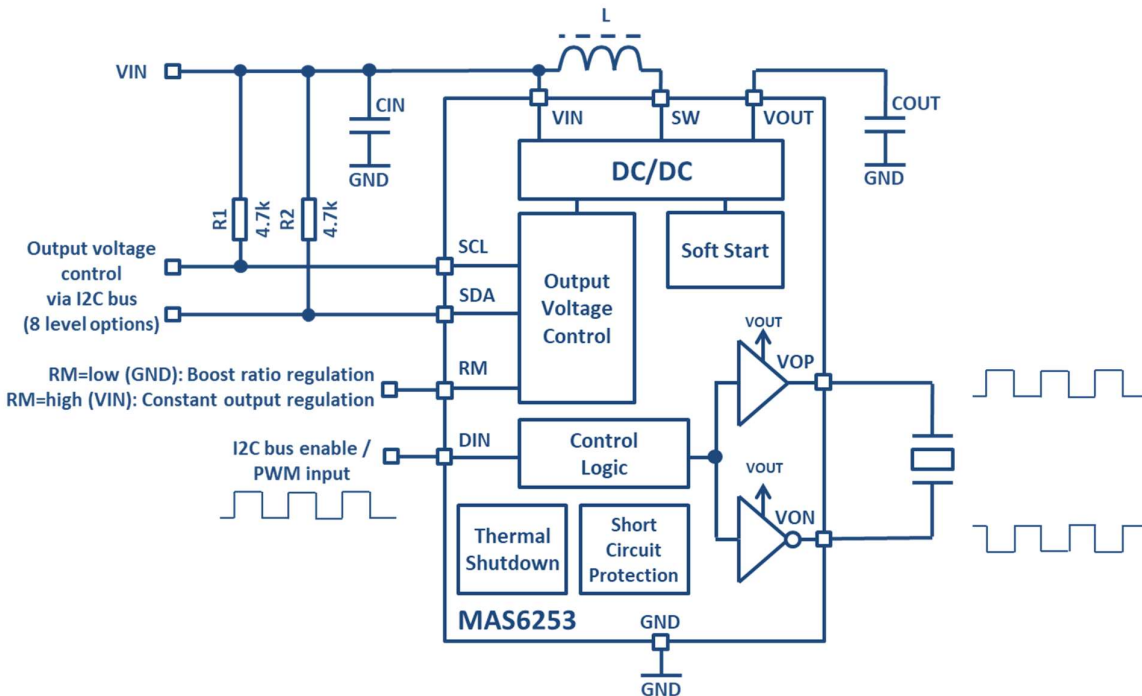

Figure 2. I2C bus controlled output voltage level. RM pin state selects output regulation mode.

APPLICATION INFORMATION

Inductor (L) selection

Shielded type inductors are recommended for low electromagnetic interference (EMI). Optimal inductance value of the inductor depends on both output power requirement and used energy source. 1 μ H inductor with higher saturation current performance is suited for the highest output power demand and high capacity and current capable Li-ion/LiPo rechargeable battery applications. 2.2 μ H inductor is recommended for coin cell (CR2032) battery applications with limited energy capacity since it offers the lowest input peak current characteristics. This is a desired feature due to high internal resistance of the CR2032 coin cell battery (10 Ω or more) and it helps keeping battery voltage ripple low.

Table 1. Recommended inductor specifications for coin cell (CR2032) and Li-ion/Li-Po battery applications

Application	Inductance	Saturation current	DC Resistance
Li-ion battery	1 μ H	≥ 1.6 A	max 0.25 Ω
Coin cell battery (CR2032)	2.2 μ H	≥ 0.75 A	max 0.5 Ω

Note: Shielded inductor recommended for low EMI. For small PCB footprint 1.6x0.8x0.8mm (0603) size DFE18SAN1R0ME0 and 2x1.6x0.9mm (0806) size LQM2MPN1R0MGHL 1 μ H inductors and 2x1.6x0.9mm (0806) size LQM2MPN2R2MGH 2.2 μ H inductor are for example available from Murata.

Input (C_{IN}) and output (C_{OUT}) capacitor value selection

The input (C_{IN}) and output (C_{OUT}) capacitors affect voltage ripple at input (V_{IN}) and output (V_{OUT}) respectively. For a proper operation and low ripple voltage they have to be low loss (low ESR) ceramic type capacitors with a sufficiently high value.

Minimum voltage rating of the input capacitor (C_{IN}) is 6.3V. Table 2 shows minimum input capacitor values in different applications and output load conditions.

Table 2. Recommended minimum input capacitor (C_{IN}) values in difference applications and load conditions

Application	C _{LOAD} =22nF	C _{LOAD} =33nF	C _{LOAD} =47nF
Li-ion/LiPo battery (internal resistance $\leq 3 \Omega$)	10 μ F	15 μ F	33 μ F
CR2032 coin cell battery (internal resistance $\geq 10 \Omega$)	47 μ F	68 μ F	10 μ F 100 μ F

Note: Input ripple voltage is proportional to piezo driver loading and inversely proportional to input capacitance (C_{IN}).

Minimum voltage rating of the output capacitor (C_{IN}) is 25V when covering the highest output voltage option. Voltage ripple (ΔV_{OUT}) at V_{OUT} output is proportional to output voltage (V_{OUT}) and ratio of piezo load capacitance (C_{LOAD}) and output capacitor (C_{OUT}) value. In differential load driving the output ripple voltage is as shown in equation 1.

$$\Delta V_{OUT} = V_{OUT} \cdot \frac{2 \cdot C_{LOAD}}{C_{OUT} + C_{LOAD}} = \frac{2 \cdot V_{OUT}}{\frac{C_{OUT}}{C_{LOAD}} + 1} \approx 2 \cdot V_{OUT} \cdot \frac{C_{LOAD}}{C_{OUT}} \quad \text{Equation 1.}$$

See table 3 showing minimum output capacitor (C_{OUT}) values for different capacitive loads (C_{LOAD}) which correspond to C_{OUT}/C_{LOAD} ratio about 21 and 9%*V_{OUT} ripple. Larger C_{OUT} capacitor values can be used to reduce the output ripple voltage lower.

Table 3. Recommended minimum output (C_{OUT}) capacitor values

Capacitor	C _{LOAD} =15nF	C _{LOAD} =22nF	C _{LOAD} =33nF	C _{LOAD} =47nF
C _{OUT} (rated voltage ≥ 25 V)	$\geq 0.33 \mu$ F	$\geq 0.47 \mu$ F	$\geq 0.68 \mu$ F	$\geq 1 \mu$ F

Note: The initial start-up time is proportional to C_{OUT}, V_{OUT} and L. Thus, larger C_{OUT}, V_{OUT} and L lead to longer start-up time.

External protection

When a mechanical or thermal shock is applied to the piezo sounder it can produce high surge voltage which may cause permanent damage to the IC. If in your application the device is expected to face such shocks you can consider using external protection against this surge voltage.

An ideal solution for external solution is using Zener diodes since it has no effect on achieved sound pressure level (SPL). See figure 3 illustrating Zener protection when driving piezo sounder in differential load configuration. The Zener voltage should be chosen high enough to not limit selected output voltage (VOUT) level but also not being too far away to provide the best protection. In case driving piezo sounder up to maximum output voltage which can be $V_{OUT}=20 + 5\% = 21V$ a suitable choice for a nominal Zener voltage is for example 22V.

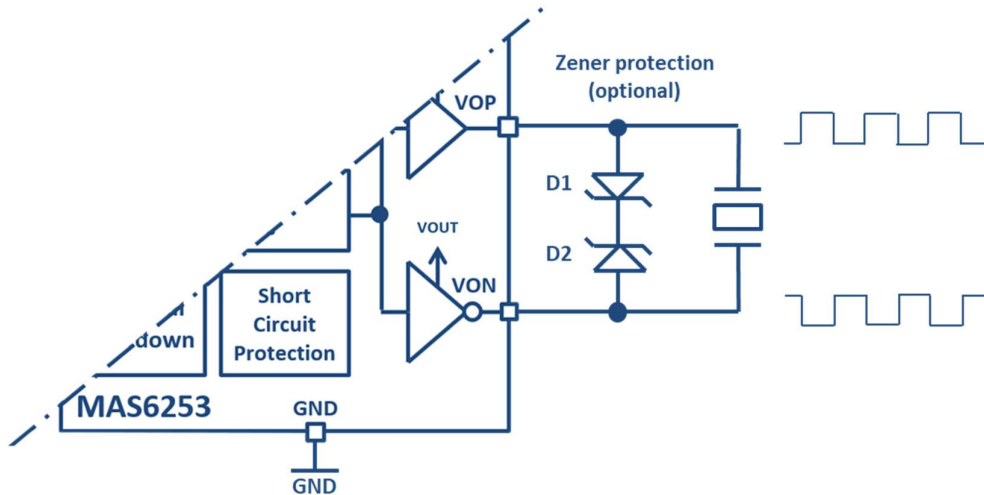

Figure 3. External Zener diode protection of piezo driver outputs

DETAILED OPERATION

◆ Operating modes

The MAS6253 has two operating modes, shutdown and active mode, which are selected by DIN pin. The DIN pin serves also as input for frequency signal which is driven to piezo sounder. By keeping DIN low makes the device to enter shutdown. When at shutdown the device draws only a minimal leakage current. When using fixed configuration for the output voltage the MAS6253 can be operated just via single DIN control pin.

The DC/DC converter is activated at third rising edge of DIN signal. The output capacitor at VOUT pin is charged to selected output voltage level employing soft-start feature to keep inrush current at low level. The piezo driver outputs are kept disabled until the output voltage (VOUT) has risen to selected output voltage level. When activated the piezo driver output VOP provides non-inverted and VON inverted signal relative to the DIN control signal polarity.

To return back to shutdown state it only requires keeping the DIN pin low for at least 20ms (typ 10ms). At shutdown both piezo driver outputs (VOP, VON) are pulled to GND (pull down resistance ~1M Ω).

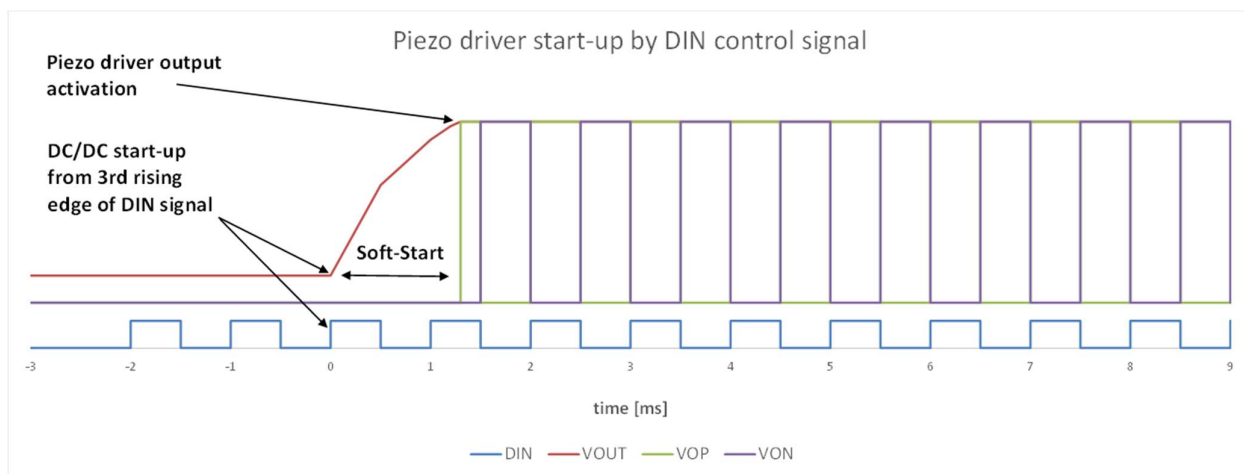

Figure 4. MAS6253 piezo driver start-up by DIN control signal

◆ Output voltage control modes

The MAS6253 supports multiple output voltage (V_{OUT}) options which are selectable either using pin control or I2C serial communication bus.

◆ Pin control mode

After power on reset (POR) the device is by default in pin control mode. In pin control mode the output voltage is selected by logic state of the SCL and SDA pins. See table 4 for the four output voltage options available in the pin control mode. Note that output voltage depends also on output regulation mode which is selected by RM pin.

Note that it is possible to select output voltages even using down to 1.2V control voltage from a low supply voltage MCU since the logic high threshold of the SCL and SDA pins is min 0.9V. See Electrical characteristics table on page 4.

◆ I2C bus control mode

In I2C bus communication the MAS6253 operates as a slave device. To activate I2C bus control mode requires following procedure. At first give one DIN=high pulse and then set DIN=high to enable the I2C bus interface. Then write an 8-bit output voltage control (OVC) data to the MAS6253 using I2C device address 0x76 (%1110110) (see figure 5). This configures the device to I2C bus control mode and output voltage selection according to given OVC value. See table 4 for eight output voltage options that are available in the I2C bus control mode. Note also that the output voltage is affected by output regulation mode which is selected by RM pin.

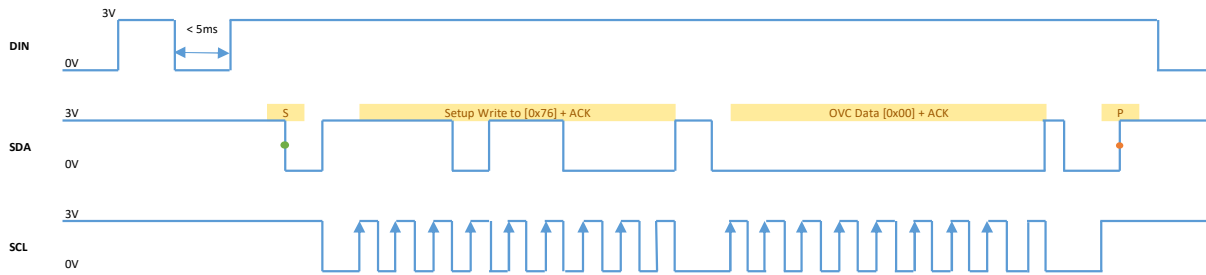
Figure 5. MAS6253 OVC register I2C write sequence

Since every power-on reset (POR) will reset the device to default pin control mode the above-described procedure is necessary after every power-up (connection of supply voltage) to keep the device in the I2C bus control mode. Also note that the DIN=high configuration must be used during every I2C bus read or write communication since the I2C bus interface is disabled when DIN=low. To minimize current consumption the DIN signal should be returned back low (I2C bus interface disabled) after I2C bus communication has been finished.

Table 4. Output voltage (V_{OUT}) options in I2C bus control and pin control modes

I2C bus control mode ⁽¹⁾ (8 settings)	Pin control mode ⁽²⁾ (4 settings)		Constant boost ratio regulation (RM=low)	Constant voltage regulation (RM=high)	Relative Audio Volume ⁽⁴⁾ [dB]	Relative current consumption ⁽⁵⁾ I_{IN} [%]	
	OVC[7-0]	SCL					SDA
XXXX X111	0xFF	low	low	$20V \cdot (V_{IN}/2.7V)$	20	0	100 %
XXXX X110	0xFE			$17.5V \cdot (V_{IN}/2.7V)$	17.5	-1.2	73 %
XXXX X101	0xFD	high	low	$15V \cdot (V_{IN}/2.7V)$	15	-2.5	55 %
XXXX X100	0xFC			$12.9V \cdot (V_{IN}/2.7V)$	12.9	-3.8	40 %
XXXX X011 (value after POR)	0xFB	high	high	$11.1V \cdot (V_{IN}/2.7V)$	11.1	-5.1	29 %
XXXX X010	0xFA			$9.5V \cdot (V_{IN}/2.7V)$	9.5	-6.5	21 %
XXXX X001	0xF9	low	high	$8.1V \cdot (V_{IN}/2.7V)$	8.1	-7.9	16 %
XXXX X000	0xF8			$7V \cdot (V_{IN}/2.7V)$	7	-9.1	12 %

X = Don't care. However, due to pull-up resistors of I2C bus choosing X=1 minimizes current consumption in the serial communication.

Note 1: In I2C bus communication mode the output voltage control (OVC) setting is accessed using I2C device address 0x76 (%1110 110). There are eight different output voltage settings available either using constant voltage regulation (RM=high) or constant voltage boost ratio regulation (RM=low). In the 8-bit output voltage control (OVC) value only the three LSB most bits are significant.

Note 2: In pin control mode there are four different output voltage settings to choose from using logic state of the SCL and SDA pins. Additionally, output voltage regulation mode is selected by RM pin.

Note 3: In constant voltage boost ratio regulation mode, the output voltage is limited to over voltage protection (OVP) level if the chosen voltage boost ratio and input voltage would otherwise lead to output voltage higher than the OVP voltage. The constant boost ratio mode output voltage options have been matched with CR2032 coin battery cell characteristics of 3V nominal voltage and 10 Ω internal resistance. In a typical piezo driving case with supply current consumption of 30mA causes about 0.3V voltage drop in the nominal voltage of the battery. This results 2.7V voltage from the battery and which has been used as a reference for the output voltage options using constant voltage boost ratio regulation.

Note 4: Relative audio volume is indicative only and based on ideal sound pressure level's logarithmic relationship to output voltage. In the table 0dB reference has been set to maximum output voltage option 20V.

Note 5: Relative current consumption estimation I_{IN} is based on page 10 equation 2 V_{OUT}^2/V_{IN} relationship and using the highest available output voltage setting as the 100% reference.

See table 5 example of I2C bus communication to select $V_{OUT}=15V$ output voltage option.

Table 5. I2C bus communication writing OVC value 0xFD ($V_{OUT}=15V$) to the MAS6523

Start	Addr Byte (0xEC / 0xED)		Ack	OVC Data (0xFD)	Ack	Stop
	Dev Addr (0x76)	Write bit (0) Read bit (1)				
S	1110 110	0	0	1111 1101	0	P

Note 1: In I2C bus communication mode the output voltage control (OVC) setting is accessed using I2C device address 0x76 (%1110 110).

Before starting I2C bus communication the I2C interface must be first activated by setting DIN=high. This setting must be used during the whole I2C bus communication. In the I2C bus protocol the data transfer starts with start

(S) condition given by the master (MCU). This is followed by 7-bit device address (0x76) and 8th read(1)/write(0) selection bit which is 0 in case of data write. Then the receiver (MAS6253) acknowledges receiving the first eight bits by pulling data line low (0). After this master (MCU) sends the eight OVC data bits which the receiver acknowledges. Communication ends to stop command sent by the master (MCU). After I2C bus communication has been finished the serial interface can be disabled by setting DIN=low to minimize current consumption.

Important note: The MAS6253 responses also to I2C devices address 0x71 (%1110 001) but which is reserved for testing purpose only. It is strictly forbidden to write any data to this test purpose reserved I2C device address since that can lead to harmful device conditions in the application circuit.

◆ Output voltage regulation modes

The MAS6253 DC/DC converter supports two output voltage regulation modes which are selected using regulation mode (RM) pin. RM=low selects constant voltage boost ratio mode and RM=high selects constant output voltage regulation mode.

In constant voltage boost ratio regulation mode (RM=low) the ratio between output and input voltages ($K_{BOOST}=V_{OUT}/V_{IN}$) is kept constant while in constant output voltage regulation mode (RM=high) the output voltage (V_{OUT}) is kept constant. The constant output voltage regulation is suitable for applications in which same sound pressure level (SPL) need to be maintained independent of the input voltage (V_{IN}). In contrast the constant voltage boost ratio regulation mode is advantageous regulation mode in coin battery cell and other current consumption critical applications since the current consumption (I_{IN}) will decrease proportionally to input voltage (V_{IN}) decreasing which helps extending battery life.

When driving capacitive piezo sounder the average current consumption (I_{IN}) is proportional to load capacitance (C_{LOAD}), drive frequency (f_{DIN}), square of drive i.e. output voltage (V_{OUT}^2) and inverse of input voltage (V_{IN}). Thus, having control on the output voltage provides method to control not only audio volume but also current consumption. See equation 2.

$$I_{IN} \sim C_{LOAD} \cdot f_{DIN} \cdot \frac{V_{OUT}^2}{V_{IN}} \quad \text{Equation 2.}$$

From equation 2 we see that in the constant output voltage (V_{OUT} fixed) regulation mode (RM=high) the current consumption is then inversely proportional to input voltage i.e. $\sim 1/V_{IN}$. Thus, current consumption increases when the input voltage decreases.

In the constant voltage boost ratio regulation mode (RM=low) the input output voltage boost ratio ($K_{BOOST}=V_{OUT}/V_{IN}$) is kept constant and the current consumption is proportional to input voltage (V_{IN}). See equation 3.

$$I_{IN} \sim C_{LOAD} \cdot f_{DIN} \cdot \left(\frac{V_{OUT}}{V_{IN}}\right)^2 \cdot V_{IN} = C_{LOAD} \cdot f_{DIN} \cdot K_{BOOST}^2 \cdot V_{IN} \quad \text{Equation 3.}$$

This characteristic makes the constant voltage boost ratio regulation very useful in battery powered systems since the current consumption decreases along with reducing battery voltage which occurs when the battery gets depleted or if it is loaded heavily. Figure 6 below shows an example of CR2032 coin battery discharging characteristics at a significant load and when using either fixed output voltage (figure on the left) or fixed boost ratio (figure on the right) regulation mode. It illustrates how significantly the fixed boost ratio regulation mode can reduce the rate that the battery voltage drops under heavy loading.

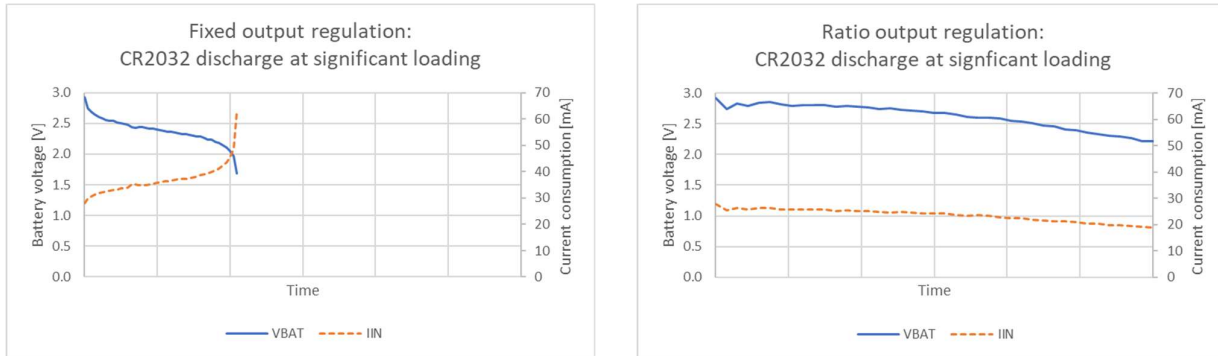

Figure 6. CR2032 battery voltage (VBAT) and converter current consumption (IIN) illustration for the two output voltage regulation modes

◆ Output voltage (V_{OUT}) and sound pressure level (SPL)

The output voltage (V_{OUT}) option table 4 includes estimation for relative audio volume (sound pressure level) in dB. This is based on piezo sounder sound pressure level (SPL [dB]) having ideally logarithmic relationship to the piezo drive voltage (V). See equation 4.

$$SPL(V) = SPL_{REF} + 20 \cdot \log\left(\frac{V}{V_{REF}}\right)$$

Equation 4.

In single-ended load configuration (load between VOP and GND) piezo drive voltage (V) is the same as the DC/DC converter output voltage (V_{OUT}). In differential load configuration (load between VOP and VON) it is twice i.e. $2 \cdot V_{OUT}$. In the equation 4 the SPL_{REF} corresponds to SPL achieved when using piezo drive voltage of V_{REF} . From this equation we get that doubling the drive voltage (V) increases SPL approximately by $20 \cdot \log(2) \sim 6\text{dB}$ and vice versa.

PRINTED CIRCUIT BOARD (PCB) LAYOUT CONSIDERATIONS

In PCB layout design the input (C_{IN}) and output (C_{OUT}) capacitors should be placed as close to the MAS6253 (U1) as possible and minimizing parasitic inductance and resistance of the PCB traces. See figure 7 for a PCB layout example of the MAS6253 configured into constant voltage boost ratio regulation mode (RM=GND) and using SDA and SCL pin state to select from four output voltage options.

In the example the most critical components of capacitors (C_{IN} , C_{OUT}) and inductor (L) have been routed on the top level to keep parasitic inductances and resistances at minimum. The SW, VOUT and GND pin traces transfer the highest currents and they have been drawn wider. The VIN pin of the MAS6253 draws only rather low operating current and it can be drawn with a normal trace width. Since SW pin is switching at high frequency the parasitic capacitances of the trace should be minimized by placing inductor connector close to the SW pin.

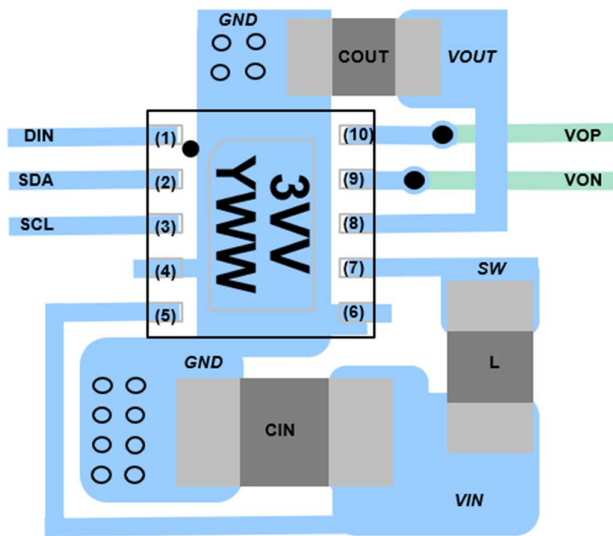
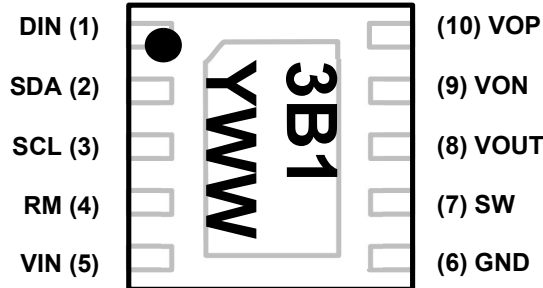

Figure 7. PCB layout example of MAS6253 piezo driver

Table 6. PCB layout example component details

Ref	Manuf. part	Value	Rating	Case inch (metric)	Dimensions (LxWxT)
U1	MAS6253	-		DFN-10	2.0x2.0x0.5 mm
CIN		47 μ F	6.3V (X5R)	0603 (1608)	1.6x0.8x0.9 mm
COUT		1 μ F	25V (X5R)	0201 (0603)	0.6x0.3x0.3 mm
L1	LQM2MPN2R2MGH	2.2 μ H	1.3A (I_{SAT})	0806 (2016)	2.0x1.6x0.9 mm

DEVICE OUTLINE CONFIGURATION



Top Marking Information:
3B1 = Product Number
YWW = Year Week

DFN-10 2.0x2.0x0.5 PIN DESCRIPTION

Pin Name	Pin	Type	Function	Note
DIN	1	DI	Device enable and Piezo frequency input	1, 4
SDA	2	DIO	Serial data pin of I2C bus control mode / Output voltage control input in pin control mode	1, 2
SCL	3	DI	Serial clock pin of I2C bus control mode / Output voltage control input in pin control mode	1, 2
RM	4	DI	Output voltage regulation mode selection input RM=high: Constant voltage regulation RM=low: Constant boost ratio regulation	1
VIN	5	P	Positive supply voltage input	
GND	6	G	Supply ground pin	
SW	7	AIO	Boost DC/DC converter switch input/output	
VOUT	8	AO	Boost DC/DC converter voltage output	
VON	9	AO	Inverted piezo driver output	
VOP	10	AO	Non-inverted piezo driver output	
EXP_PAD	-	G	Exposed thermal pad	3

G = Ground, P = Power, D = Digital, A = Analog, I = Input, O = Output

Note 1: Digital inputs or serial bus communication can be driven from 1.2V up to 5.5V level logic outputs. DIN pin has active pull-down by 400kΩ which is disabled to save current when inputs are pulled high (≥0.9V).

Note 2: Output voltage selection is done via SDA and SCL pins either based on pin state or via I2C bus communication

Note 3: On PCB the exposed thermal pad must be connected to GND plane using thermal vias functioning as thermal heat sink

Note 4: DIN pin must be at high level during I2C bus communication

PACKAGE (DFN-10 2x2x0.75) OUTLINE

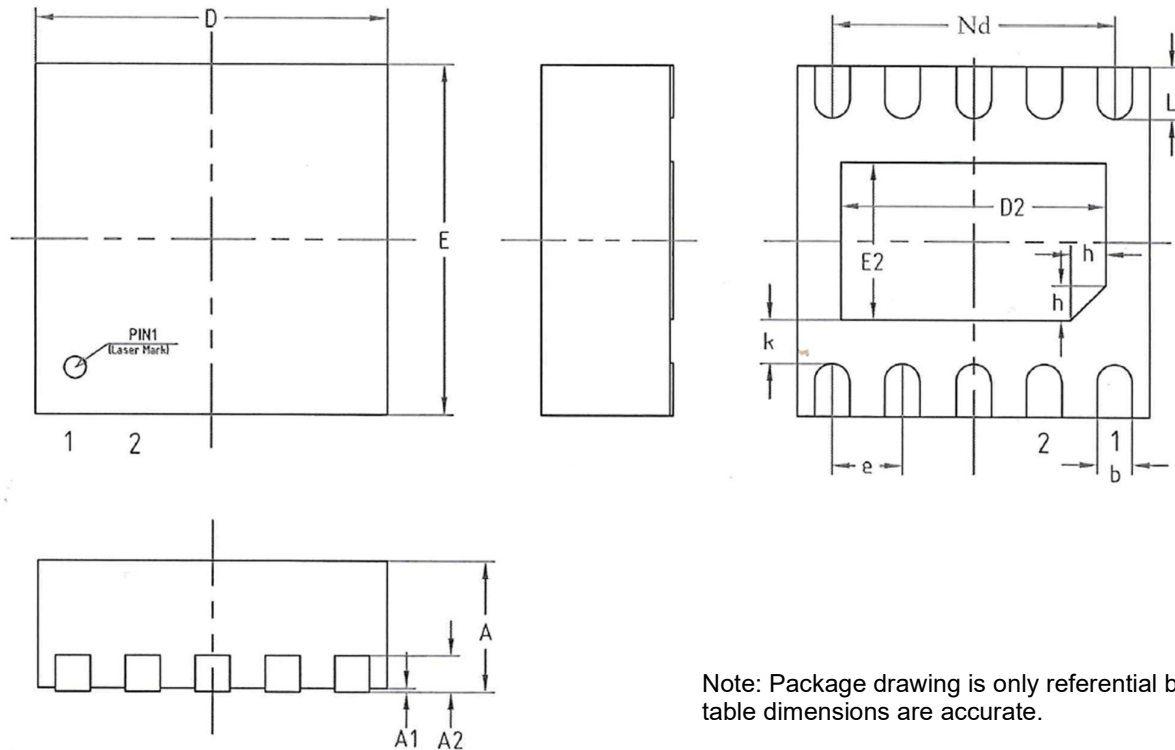

Note: Package drawing is only referential but table dimensions are accurate.

Symbol	Min	Nom	Max	Unit
PACKAGE DIMENSIONS				
A	0.70	0.75	0.80	mm
A1	-	0.02	0.05	mm
A2	0.203 REF			
b	0.15	0.20	0.25	mm
D	1.90	2.00	2.10	mm
D2 (Exposed.pad)	1.45	1.50	1.55	mm
E	1.90	2.00	2.10	mm
E2 (Exposed.pad)	0.85	0.90	0.95	mm
e	0.40 BSC			mm
K	0.20	0.25	0.30	mm
L	0.25	0.30	0.35	mm
h	0.15	0.20	0.25	mm
Nd	1.60 BSC			mm

Dimensions do not include mold or interlead flash, protrusions or gate burrs.

SOLDERING INFORMATION

◆ For Lead-Free / Green DFN 2mm x 2mm x 0.5mm and DFN 2mm x 2mm x 0.75mm

Resistance to Soldering Heat	According to RSH test IEC 68-2-58/20
Maximum Temperature	260°C
Maximum Number of Reflow Cycles	3
Reflow profile	Thermal profile parameters stated in IPC/JEDEC J-STD-020 should not be exceeded. http://www.jedec.org
Lead Finish	7.62 - 25.4 μm, Matte Tin
Moisture Sensitivity Level (MSL)	2 (per J-STD-020)

ORDERING INFORMATION

Product Code	Product	Package	Comments
MAS6253BA1D1206	Piezo Driver with Synchronous Boost DC/DC Converter	DFN-10 2.0x2.0x0.5, REACH & RoHS Compliant	Tape and Reel 3000 pcs / r
MAS6253BA1D1306	Piezo Driver with Synchronous Boost DC/DC Converter	DFN-10 2.0x2.0x0.75, REACH & RoHS Compliant	Tape and Reel 3000 pcs / r

LOCAL DISTRIBUTOR

--

MICRO ANALOG SYSTEMS OY CONTACTS

Micro Analog Systems Oy Kutomotie 16 FI-00380 Helsinki, FINLAND	Tel. +358 10 835 1100 http://www.mas-oy.com
---	--

NOTICE

Micro Analog Systems Oy (MAS) reserves the right to make changes to the products contained in this data sheet in order to improve the design or performance and to supply the best possible products. MAS assumes no responsibility for the use of any circuits shown in this data sheet, conveys no license under any patent or other rights unless otherwise specified in this data sheet, and makes no claim that the circuits are free from patent infringement. Applications for any devices shown in this data sheet are for illustration only and MAS makes no claim or warranty that such applications will be suitable for the use specified without further testing or modification.

MAS products are not authorized for use in safety-critical applications (such as life support) where a failure of the MAS product would reasonably be expected to cause severe personal injury or death. Buyers represent that they have all necessary expertise in the safety and regulatory ramifications of their applications, and acknowledge and agree that they are solely responsible for all legal, regulatory and safety-related requirements concerning their products and any use of MAS products in such safety-critical applications, notwithstanding any applications-related information or support that may be provided by MAS. Further, Buyers must fully indemnify MAS and its representatives against any damages arising out of the use of MAS products in such safety-critical applications.

MAS products are neither designed nor intended for use in military/aerospace applications or environments. Buyers acknowledge and agree that any such use of MAS products which MAS has not designated as military-grade is solely at the Buyer's risk, and that they are solely responsible for compliance with all legal and regulatory requirements in connection with such use.

MAS products are neither designed nor intended for use in automotive applications or environments. Buyers acknowledge and agree that, if they use any non-designated products in automotive applications, MAS will not be responsible for any failure to meet such requirements.