

MAS6502

DATA SHEET EXTENSION

- Writing data to the EEPROM

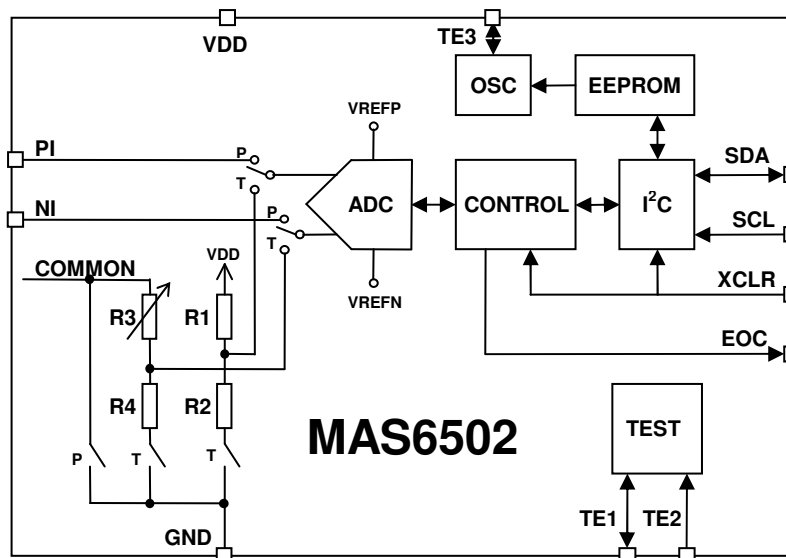

INTRODUCTION

The MAS6502 16 bit Analog-to-Digital Converter (ADC) has a 256 bit (32 bytes) EEPROM memory. 8 bits (1 byte) have been reserved for storing internal clock oscillator trimming data leaving 248 bits (31 bytes) free for use.

This document gives instructions for writing data to the EEPROM memory.

EEPROM WRITE PROCEDURE

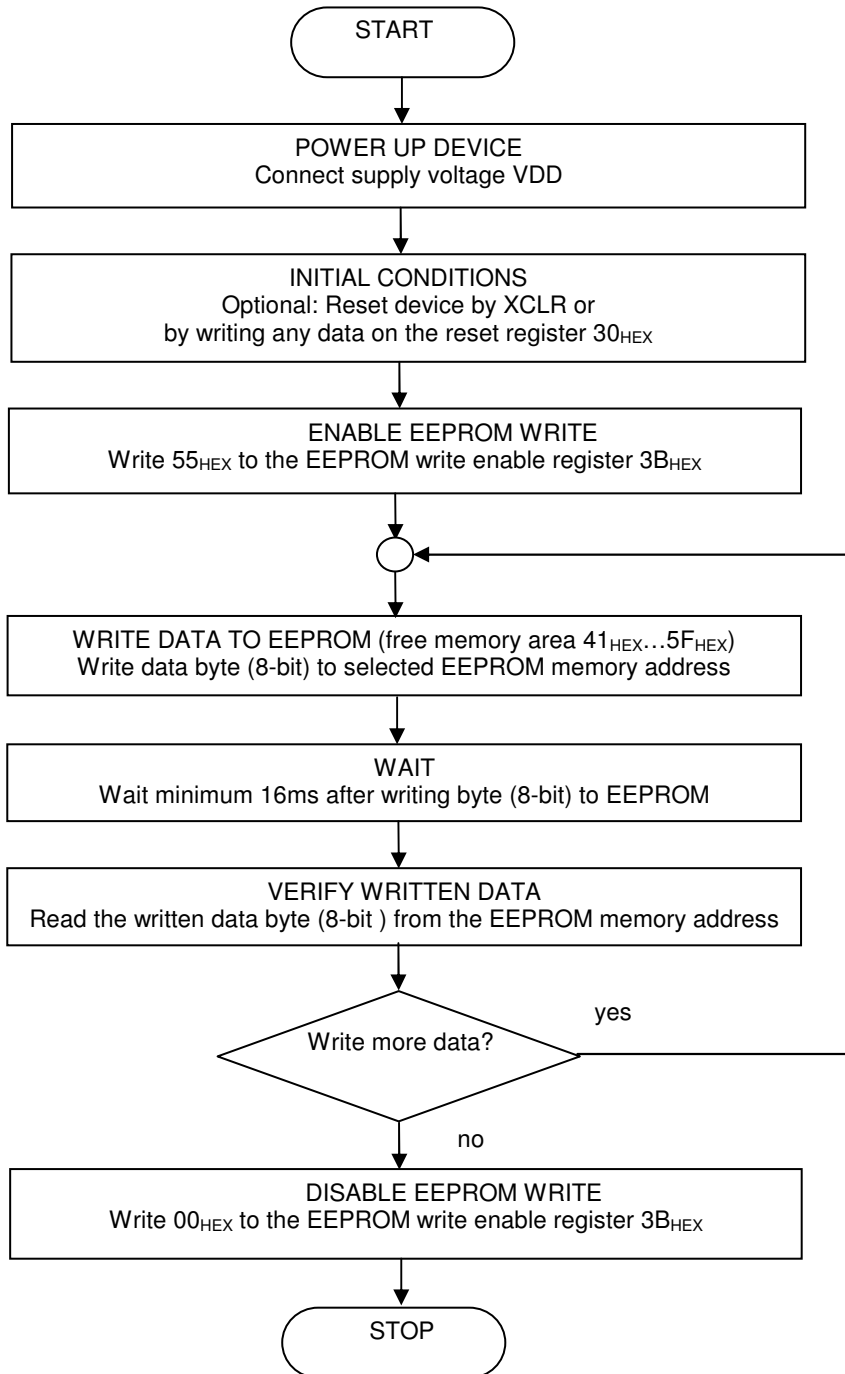

Figure 1. Flow chart for MAS6502 EEPROM write

EEPROM WRITE PROCEDURE

See figure 1 on previous page showing the EEPROM write procedure.

Make sure in the beginning of the EEPROM write procedure that the MAS6502 initial conditions are met. Connecting VDD triggers power-on-reset (POR) but to make sure the device is reset an additional reset can be given using the XCLR pin or writing any data on the reset register 30_{HEX} via I²C serial bus.

EEPROM write is enabled by writing value 55_{HEX} to EEPROM write enable register 3B_{HEX}. Any other value in this register disables the EEPROM write. The default register value after power on is 00_{HEX}.

Next the data can be written to the EEPROM memory one byte (8-bit) at a time. It is necessary to have a delay of minimum 16ms after programming each byte (8-bit). The success of each write can be verified by reading back the data (8-bit) and comparing it to the original byte (8-bit).

After all data bytes are written the EEPROM memory can be protected from write and erasing by writing 00_{HEX} to the EEPROM write enable register 3B_{HEX}.

Table 1 below shows the MAS6502 register and EEPROM data addresses. See also the MAS6502 datasheet for further details of registers, EEPROM and serial bus communication.

REGISTER AND EEPROM DATA ADDRESSES

Table 1. Register and EEPROM data addresses

A7	A6	A5	A4	A3	A2	A1	A0	HEX (X=0)	Description	Note
X	0	0	0	0	0	0	0	00	EEPROM; erase internal clock oscillator trimming, reserved!	E
X	0	0	A4	A3	A2	A1	A0	01...1F	EEPROM; erase data at address [A4:A0]	E
X	1	0	0	0	0	0	0	40	EEPROM; read or write internal clock oscillator trimming, reserved!	E
X	1	0	A4	A3	A2	A1	A0	41...5F	EEPROM; read or write data at address [A4:A0]	E
X	X	1	1	0	0	0	0	30	Reset register; contains no data, write any data for reset	R
X	X	1	1	0	1	1	1	37	Test and trim control register	R
X	X	1	1	1	0	0	0	38	Oscillator frequency control register	R
X	X	1	1	1	0	0	1	39	Data input register for EEPROM	R
X	X	1	1	1	0	1	0	3A	Control register for EEPROM	R
X	X	1	1	1	0	1	1	3B	Write and erase enable for EEPROM	R
X	X	1	1	1	1	0	0	3C	Status register for EEPROM	R
X	X	1	1	1	1	0	1	3D	MSB conversion result	R
X	X	1	1	1	1	1	0	3E	LSB conversion result	R
X	X	1	1	1	1	1	1	3F	ADC control register	R

X = Don't care, E = EEPROM, R= Register

MICRO ANALOG SYSTEMS OY CONTACTS

Micro Analog Systems Oy Kutomotie 16 FI-00380 Helsinki, FINLAND	Tel. +358 10 835 1100 Fax +358 10 835 1109 http://www.mas-oy.com
---	--

NOTICE

Micro Analog Systems Oy reserves the right to make changes to the products contained in this data sheet in order to improve the design or performance and to supply the best possible products. Micro Analog Systems Oy assumes no responsibility for the use of any circuits shown in this data sheet, conveys no license under any patent or other rights unless otherwise specified in this data sheet, and makes no claim that the circuits are free from patent infringement. Applications for any devices shown in this data sheet are for illustration only and Micro Analog Systems Oy makes no claim or warranty that such applications will be suitable for the use specified without further testing or modification.