

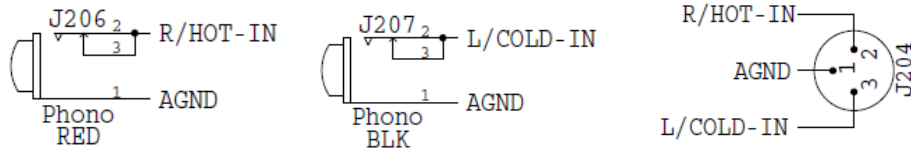

## CONNECTIONS

### Board front

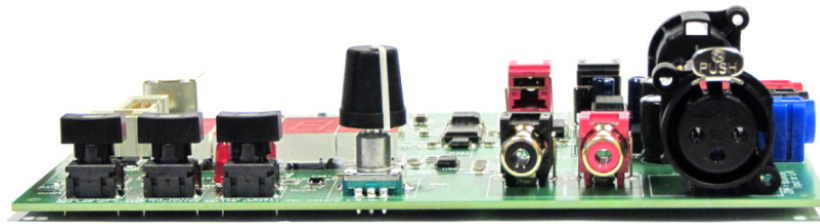

The front of the board has three audio connectors. The right hand XLR socket is for balanced audio in; the two phono sockets are for single ended audio in, with red the right channel and black the left channel.

### Board side

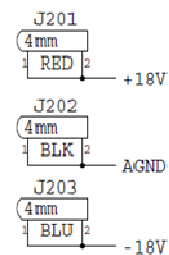
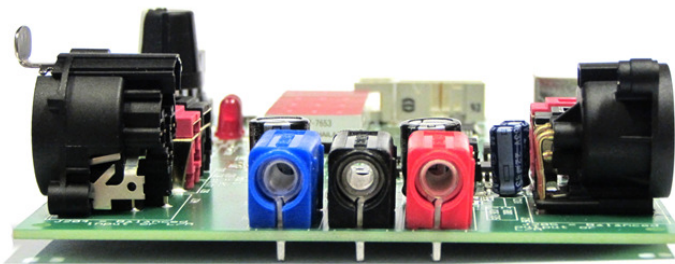

The side of the board has three connectors for analogue power. The red is +V, blue -V and black analogue ground. Maximum voltages are in the recommended operating conditions section.

### Board back

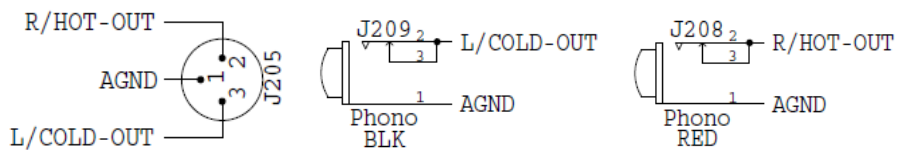
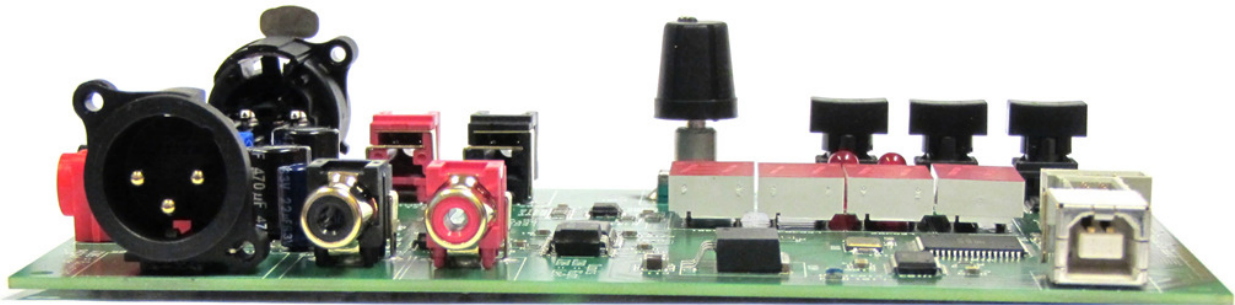

The back of the board has audio out connectors and the USB connector. The XLR on the left is for balanced audio. The two phono connectors are for single ended signals, black for the left channel and red for the right channel.

On the right hand side is the USB connector for digital power and for connection to the GUI interface and control via a computer.

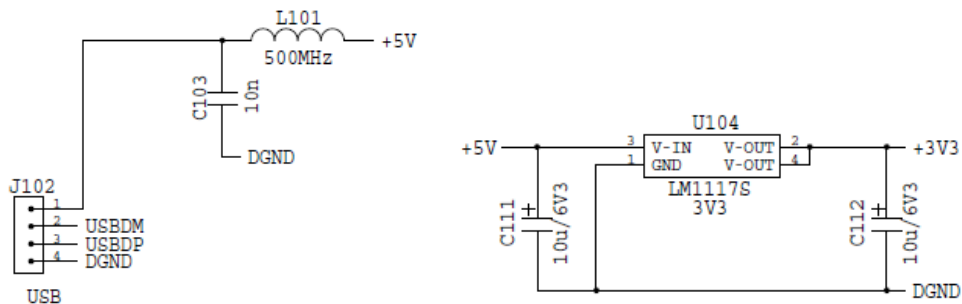

The digital section is powered from the USB connector. It can be powered from a standalone power supply with a USB plug as long as it complies with the specifications given in the section "Recommended operating conditions".

## OPERATION

### Standalone usage

In standalone mode it is possible to adjust left and right gain, set the peak level and mute the output. Levels are adjusted by turning the rotary encoder. The levels to adjust are selected by the three switches.

By pressing the left switch, the left channel is selected, the right switch selects the right channel and both left and right mean both left and right levels will simultaneously be altered.

The left and right switches work in the following way:

If neither is on (red = selected, green = inactive), pressing one switch will activate it and only it. If one is illuminated (red) and the other is pressed, both will be active. Pressing either of the two active switches will then deactivate (green) that switch.

By pressing the peak switch, the peak level is adjusted when the rotary encoder is turned.

The rotary encoder has an integral switch. Depressing the switch toggles mute on and off.

### GUI Program

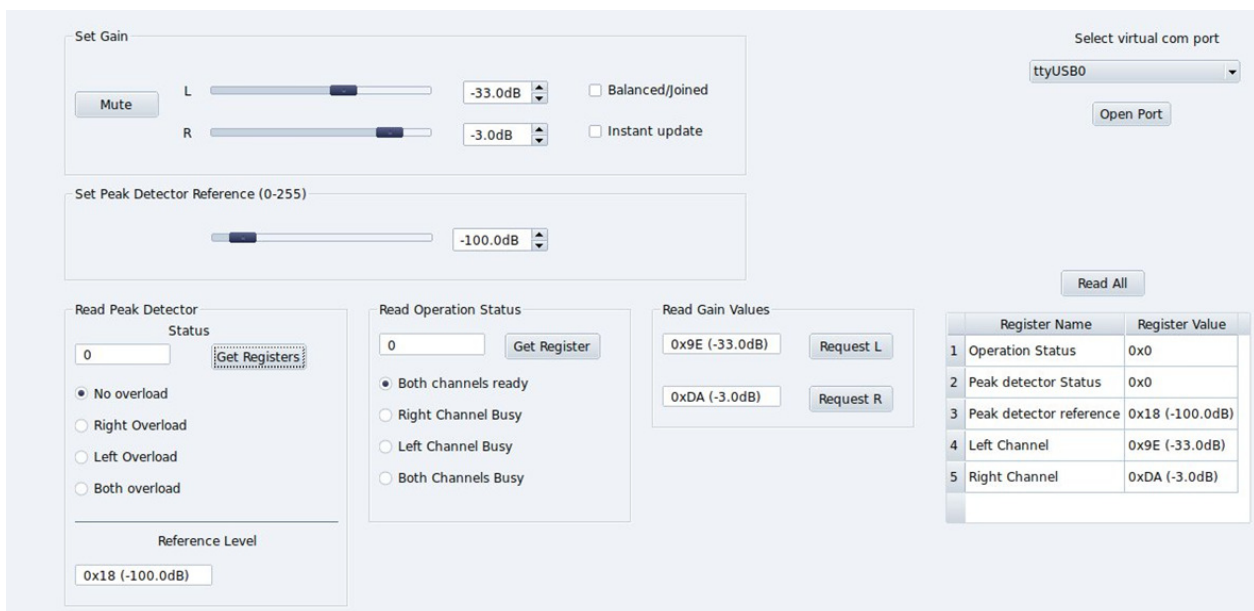

The screenshot shows the GUI interface for the MAS6116. It includes sections for setting gain (L and R channels), peak detector reference, reading peak detector status, reading operation status, reading gain values, and a table of register names and values.

Register Name	Register Value
1 Operation Status	0x0
2 Peak detector Status	0x0
3 Peak detector reference	0x18 (-100.0dB)
4 Left Channel	0x9E (-33.0dB)
5 Right Channel	0xDA (-3.0dB)

The GUI program runs on Linux, Windows and Mac OS X. All functions of the MAS6116 can be changed from and read by the program. There is only one screen and all functions can be changed from this screen.

First, the GUI has to be connected to the board by selecting the appropriate virtual com port from the drop down box and clicking the connect button.

The functions are grouped together, with the gains and the peak level set by sliders. The levels can also be changed in half decibel steps by the spin boxes to the right of the sliders. When the levels are changed, the mode of the board is automatically changed.

The register values can be read by pressing the read registers button. The values are displayed in hex.

---

**RECOMMENDED OPERATING CONDITIONS**

---

**Analogue Section** All voltages with respect to analogue ground (AGND)

Parameter	Symbol	Min	Max
Positive Supply Voltage	+V	+5V	+17.5V
Negative Supply Voltage	-V	-5V	-17.5V
Analogue signal	Vin	-V	+V

**Digital section** (Voltage with respect to DGND)

Parameter	Symbol	Min	Max
Positive supply	Vcc	+3.9V	6V

The digital section is powered from the USB connector. It can be powered from a standalone power supply with a USB plug as long as it falls within the above parameters.

## CIRCUIT BOARD SCHEMATIC

The board uses an OPA2277PA dual operational amplifier in a DIP8 package. This device is mounted on the board via a socket and is easy to replace for customer who wants to test the performance of other operational amplifiers.

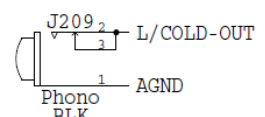
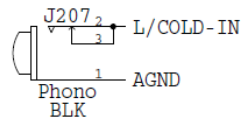
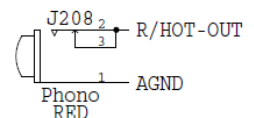
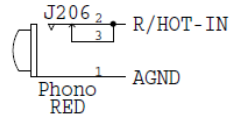
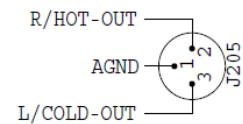
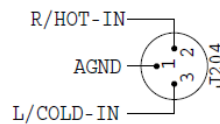
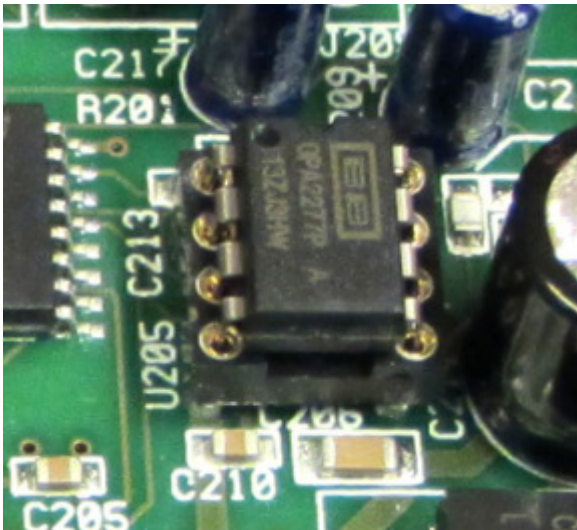
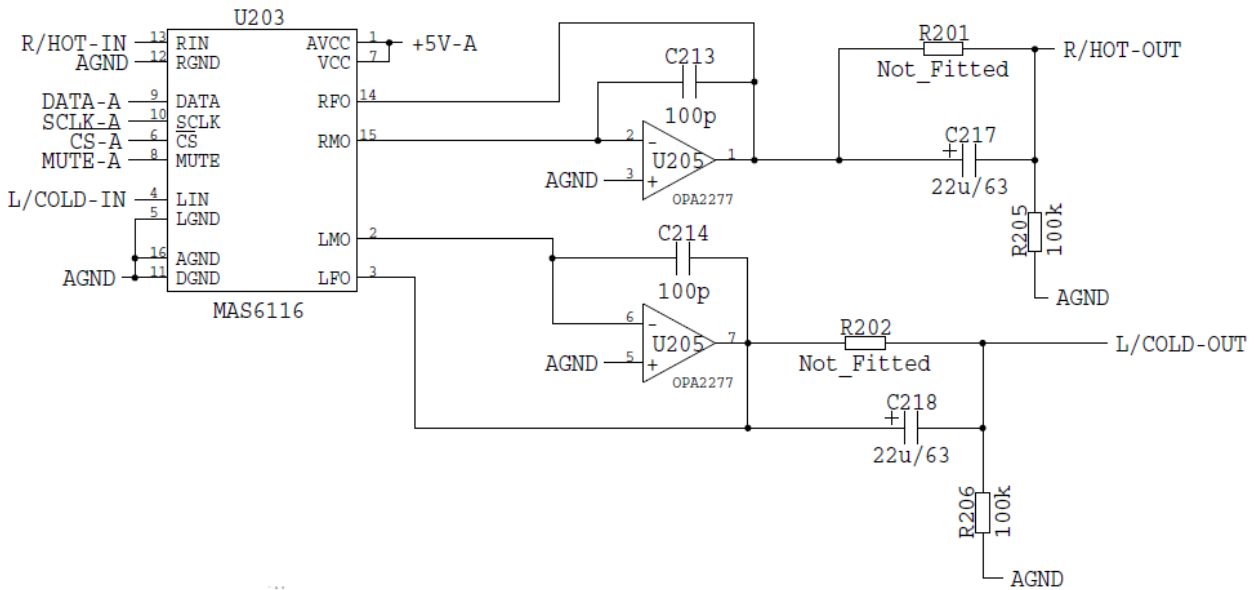

For the complete schematic please see separate PDF file.

---

## ORDERING INFORMATION

---

Product Code	Product	Package	Comments
EB6116AA1SA3	MAS6116 Evaluation Board	SOIC-16	

---

## LOCAL DISTRIBUTOR

---

---

## MICRO ANALOG SYSTEMS OY CONTACTS

---

Micro Analog Systems Oy Kutomotie 16 FI-0038 Helsinki, FINLAND	Tel. +358 10 835 1100 Fax +358 10 835 1119 <a href="http://www.mas-oy.com">http://www.mas-oy.com</a>
--	--

### NOTICE

Micro Analog Systems Oy reserves the right to make changes to the products contained in this data sheet in order to improve the design or performance and to supply the best possible products. Micro Analog Systems Oy assumes no responsibility for the use of any circuits shown in this data sheet, conveys no license under any patent or other rights unless otherwise specified in this data sheet, and makes no claim that the circuits are free from patent infringement. Applications for any devices shown in this data sheet are for illustration only and Micro Analog Systems Oy makes no claim or warranty that such applications will be suitable for the use specified without further testing or modification.