

MAS6180B

AM Receiver IC

- **Single Band Receiver IC**
- **High Sensitivity**
- **Very Low Power Consumption**
- **Wide Supply Voltage Range**
- **Power Down Control**
- **Control for AGC On**
- **High Selectivity by Crystal Filter**
- **Fast Startup Feature**

DESCRIPTION

The MAS6180 AM-Receiver chip is a highly sensitive, simple to use AM receiver specially intended to receive time signals in the frequency range from 40 kHz to 100 kHz. Only a few external components are required for time signal receiver. The circuit has preamplifier, wide range automatic gain control, demodulator and output comparator built in. The output signal can be processed directly by an additional digital circuitry to extract the

data from the received signal. The control for AGC (automatic gain control) can be used to switch AGC on or off if necessary.

MAS6180 has two options for compensating shunt capacitances of different crystals (See ordering information on page 13).

FEATURES

- Single Band Receiver IC
- Highly Sensitive AM Receiver
- Wide Supply Voltage Range from 1.1 V to 3.6 V
- Very Low Power Consumption
- Power Down Control
- Fast Startup
- Only a Few External Components Necessary
- Control for AGC On
- Wide Frequency Range from 40 kHz to 100 kHz
- High Selectivity by Quartz Crystal Filter
- Crystal Compensation Capacitance Options
- Differential Input

APPLICATIONS

- Single Band Time Signal Receiver WWVB (USA), JJY (Japan), DCF77 (Germany), MSF (UK), HBG (Switzerland) and BPC (China)

BLOCK DIAGRAM

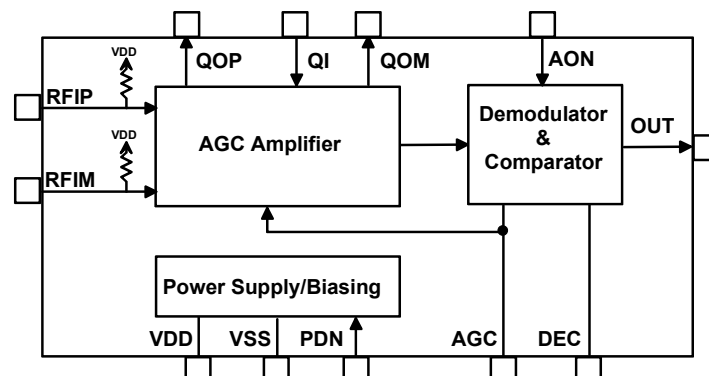

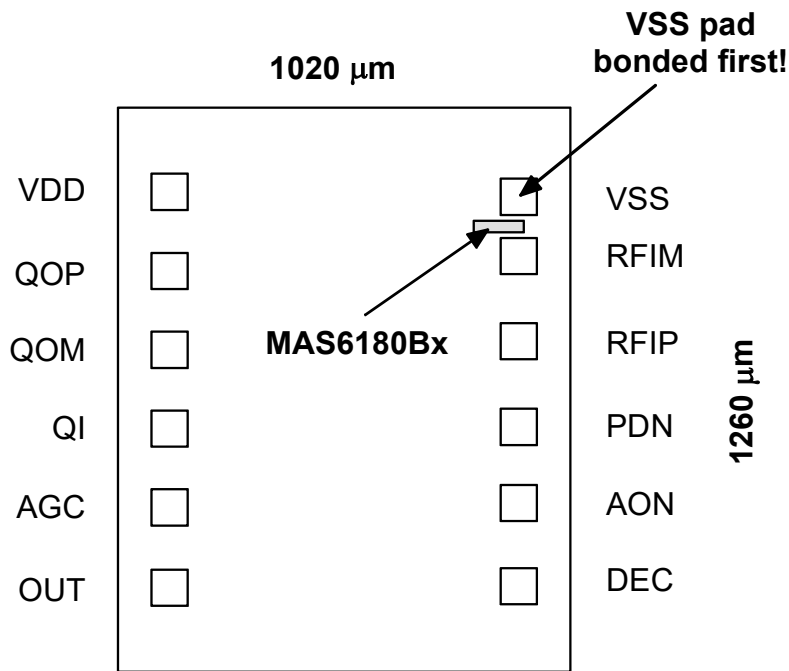
MAS6180 PAD LAYOUT

DIE size = 1020 μm x 1260 μm; PAD size = 80 μm x 80 μm

Note: Because the substrate of the die is internally connected to VSS, the die has to be connected to VSS or left floating. Please make sure that VSS is the first pad to be bonded. Pick-and-place and all component assembly are recommended to be performed in ESD protected area.

Note: Coordinates are pad center points where origin has been located in bottom-left corner of the silicon die.

Pad Identification	Name	X-coordinate	Y-coordinate	Note
Power Supply Voltage	VDD	126 μm	1062 μm	
Positive Quartz Filter Output for Crystal	QOP	126 μm	893 μm	
Negative Quartz Filter Output for Crystal	QOM	126 μm	723 μm	1
Quartz Filter Input for Crystal and External Compensation Capacitor	QI	126 μm	549 μm	
AGC Capacitor	AGC	126 μm	375 μm	
Receiver Output	OUT	126 μm	198 μm	2
Demodulator Capacitor	DEC	894 μm	201 μm	
AGC On Control	AON	894 μm	385 μm	3
Power Down	PDN	894 μm	553 μm	4
Positive Receiver Input	RFIP	894 μm	742 μm	5
Negative Receiver Input	RFIM	894 μm	920 μm	5
Power Supply Ground	VSS	894 μm	1051 μm	

Notes:

- External crystal compensation capacitor pin QOM is connected only in MAS6180B5 version. It is left unconnected in MAS6180B1 version which has internal compensation capacitor.
- OUT = VSS when carrier amplitude at maximum; OUT = VDD when carrier amplitude is reduced (modulated)
 - The output is a current source/sink with $|I_{OUT}| > 5 \mu A$
 - At power down the output is pulled to VSS (pull down switch)
- AON = VSS means AGC off (hold current gain level); AON = VDD means AGC on (normal operation)
 - Unused AON pad can be left unconnected due to internal pull-up with current $< 1 \mu A$. Pull up current is switched off at power down.
- PDN = VSS means receiver on; PDN = VDD means receiver off
 - Fast start-up is triggered when the receiver is after power down (PDN=VDD) controlled to power up (PDN=VSS) i.e. at the falling edge of PDN signal.
- Receiver inputs RFIP and RFIM have both 1.4 MΩ biasing resistors towards VDD

ABSOLUTE MAXIMUM RATINGS

All Voltages with Respect to Ground

Parameter	Symbol	Conditions	Min	Max	Unit
Supply Voltage	$V_{DD}-V_{SS}$		- 0.3	3.6	V
Input Voltage	V_{IN}		$V_{SS}-0.3$	$V_{DD}+0.3$	V
Operating Temperature	T_{OP}		-40	+85	°C
Storage Temperature	T_{ST}		- 55	+150	°C

Note: Stresses beyond those listed may cause permanent damage to the device. The device may not operate under these conditions, but it will not be destroyed.

Note: This is a CMOS device and therefore it should be handled carefully to avoid any damage by static voltages (ESD).

ELECTRICAL CHARACTERISTICS

 Operating Conditions: $V_{DD} = 1.5V$, Temperature = 27°C, unless otherwise specified.

Parameter	Symbol	Conditions	Min	Typ	Max	Unit
Operating Voltage	V_{DD}		1.1	1.5	3.6	V
Current Consumption	I_{DD}	$V_{DD}=1.5V, V_{in}=0\mu V_{rms}$ $V_{DD}=1.5V, V_{in}=20mV_{rms}$ $V_{DD}=3.6V, V_{in}=0\mu V_{rms}$ $V_{DD}=3.6V, V_{in}=20mV_{rms}$	31 24	66 40 68 42	85 65	μA
Stand-By Current	I_{DDoff}	See note below.			0.1	μA
Input Frequency Range	f_{IN}		40		100	kHz
Minimum Input Voltage	V_{INmin}			0.4	1	μV_{rms}
Maximum Input Voltage	V_{INmax}		20			mVrms
Receiver Input Resistance	R_{RFI}	Differential Input, $f=40kHz \dots 77.5kHz$		600		k Ω
Receiver Input Capacitance	C_{RFI}			1.1		pF
Input Levels $ I_{IN} < 0.5\mu A$	V_{IL} V_{IH}		$V_{DD}-0.35$		0.35	V
Output Current $V_{OL} < 0.2V_{DD}; V_{OH} > 0.8V_{DD}$	$ I_{OUT} $		5			μA
DCF77 Output Pulses	T_{100ms} T_{200ms}	$1\mu V_{rms} \leq V_{IN} \leq 20mV_{rms}$, see note below!		95 195		ms
MSF Output Pulses	T_{100ms} T_{200ms} T_{300ms} T_{500ms}	$1\mu V_{rms} \leq V_{IN} \leq 20mV_{rms}$, see note below!		120 220 320 520		ms
WWVB Output Pulses	T_{200ms} T_{500ms} T_{800ms}	$1\mu V_{rms} \leq V_{IN} \leq 20mV_{rms}$, see note below!		200 500 800		ms
JJY60 Output Pulses	T_{200ms} T_{500ms} T_{800ms}	$1\mu V_{rms} \leq V_{IN} \leq 20mV_{rms}$, see note below!		210 505 800		ms
JJY40 Output Pulses	T_{200ms} T_{500ms} T_{800ms}	$1\mu V_{rms} \leq V_{IN} \leq 20mV_{rms}$, see note below!		200 495 790		ms
Startup Time	T_{Start}	Fast Start-up, $V_{in}=0.4\mu V_{rms}$ Fast Start-up, $V_{in}=20mV_{rms}$		1.3 3.5		s
Output Delay Time	T_{Delay}			50	100	ms

Note: Stand-by current consumption may increase if V_{IH} and V_{IL} differ from V_{DD} and 0 respectively.

Note: See Note 6: Time Signal Software's Pulse Width Recognition Limits and Table 5 on page 8!

TYPICAL APPLICATION

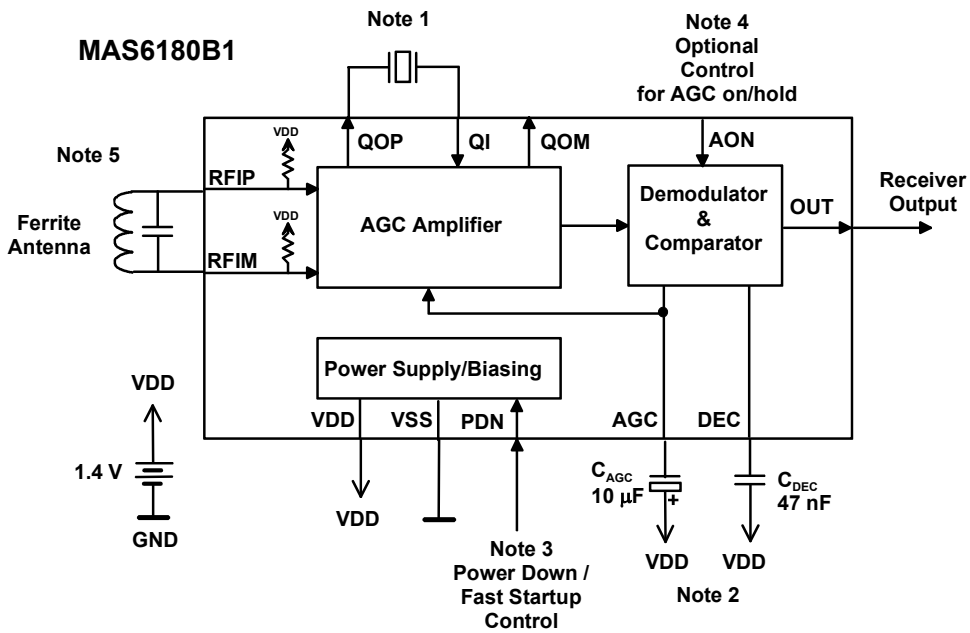

Figure 1. Application circuit of internal compensation capacitance option version MAS6180B1.

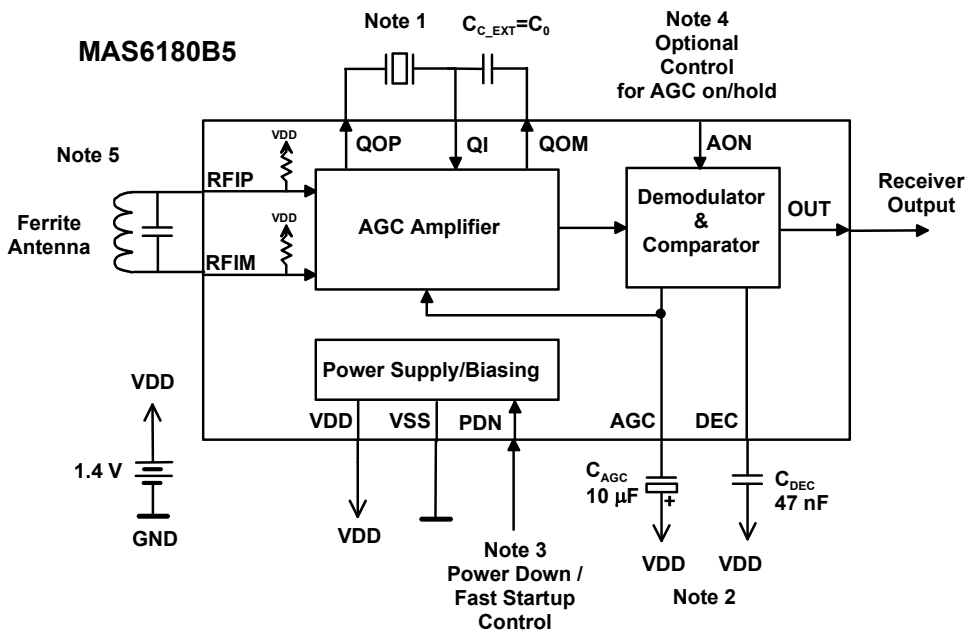

Figure 2. Application circuit of external compensation capacitance option version MAS6180B5.

TYPICAL APPLICATION (Continued)

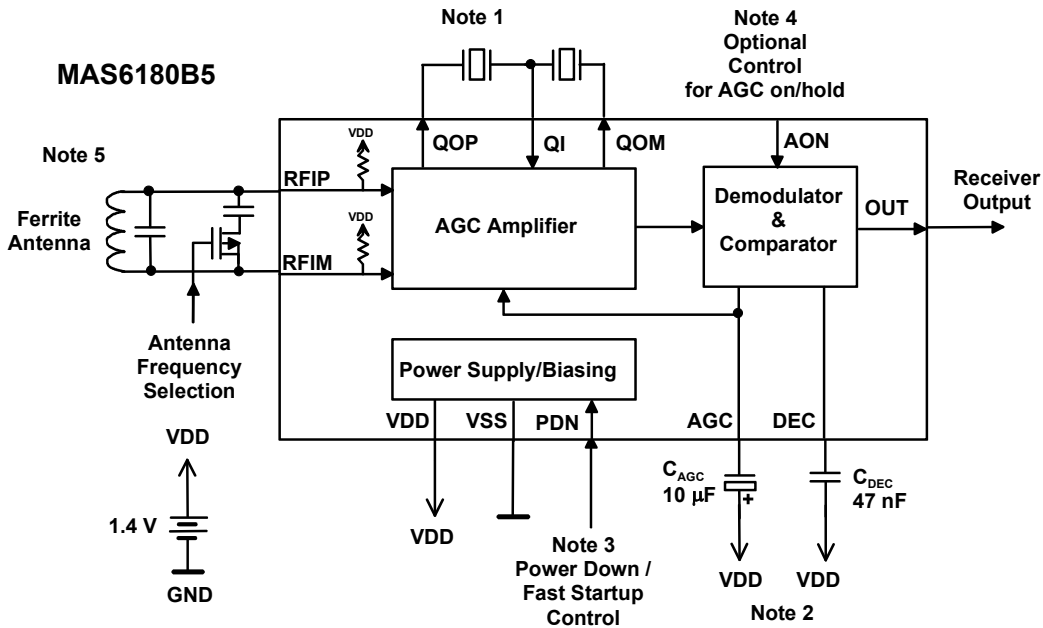

Figure 3. Dual band application circuit of external compensation capacitance option version MAS6180B5. PMOS switch transistor is used since RFIM input is biased close to VDD voltage.

TYPICAL APPLICATION (Continued)

Note 1: Crystals

The crystal as well as ferrite antenna frequencies are chosen according to the time-signal system (Table 1). More detailed crystal nominal frequency is normally specified for certain load capacitance but in MAS6180 filter circuit the load capacitance is not used. Effectively this means that most accurate filter frequency is achieved by using about 3 Hz higher frequency crystal than the received time signal frequency. For example in DCF77 application a 77.503 kHz crystal resonates at the desired DCF77 77.500 kHz frequency when the load capacitor is missing.

Table 1. Time-Signal System Frequencies

Time-Signal System	Location	Antenna Frequency	Recommended Crystal Frequency
DCF77	Germany	77.5 kHz	77.503 kHz
HBG	Switzerland	75 kHz	75.003 kHz
MSF	United Kingdom	60 kHz	60.003 kHz
WWVB	USA	60 kHz	60.003 kHz
JJY	Japan	40 kHz and 60 kHz	40.003 kHz and 60.003 kHz
BPC	China	68.5 kHz	68.505 kHz

The crystal shunt capacitance C_0 should be matched as well as possible with the internal shunt capacitance compensation capacitor C_c of MAS6180. MAS6180B5 is option for external crystal compensation capacitor. The external compensation capacitor should be matched similarly as well as possible with crystal's shunt capacitance. See Compensation Capacitance Options on table 2.

Table 2. Compensation Capacitance Options

Device	C_c	Crystal Description
MAS6180B1	0.75 pF	For low C_0 crystals
MAS6180B5	C_{c_EXT}	For any crystals, external compensation capacitor

It should be noted that grounded crystal package has reduced shunt capacitance. This value is about 85% of floating crystal shunt capacitance. For example crystal with 1 pF floating package shunt capacitance can have 0.85 pF grounded package shunt capacitance. PCB traces of crystal and external compensation capacitance should be kept at minimum to minimize additional parasitic capacitance which can cause capacitance mismatching.

In dual band receiver configuration the crystals are best to connect as shown in figure 3. In this configuration the crystals' shunt capacitances compensate each other and external compensation capacitor is not needed at all.

Table 3 below presents some crystal suppliers having suitable crystals for time signal receiver application.

Table 3. Crystal Suppliers and Crystal Types in Alphabetical Order for Time Signal Receiver Application

Supplier	Crystal Type	Dimensions	Web Link
Citizen	CFV-206	ø 2.0 x 6.0	http://www.citizen.co.jp/tokuhan/quartz/
Epson Toyocom	C-2-Type C-4-Type	ø 1.5 x 5.0 ø 2.0 x 6.0	http://www.epsontoyocom.co.jp/english/
KDS Daishinku	DT-261	ø 2.0 x 6.0	http://www.kds.info/index_en.htm
Microcrystal	MS3V-T1R	1.45 x 1.45 x 6.7	http://www.microcrystal.com/
Seiko Instruments	VTC-120	ø 1.2 x 4.7	http://www.sii-crystal.com

TYPICAL APPLICATION (Continued)

Note 2: AGC Capacitor

The AGC and DEC capacitors must have low leakage currents due to very small signal currents through the capacitors. The insulation resistance of these capacitors should be at minimum 100 MΩ. Also probes with at least few 100 MΩ impedance should be used for voltage probing of the AGC and DEC pins. Electrolytic AGC capacitor should have voltage rating at least 25 V for low enough leakage. DEC capacitor can be low leakage chip capacitor. It is recommended to connect both AGC and DEC capacitors to VDD (see application figures 1, 2 and 3) although VSS connection is also possible. The VDD connection provides better supply noise immunity because signals are referenced to VDD. Additionally leakage currents are minimized in this connection because in power down the AGC pin voltage is pulled to VDD (to minimum AGC gain) then corresponding to zero voltage over the AGC capacitor.

Note 3: Power Down / Fast Startup Control

Both power down and fast startup are controlled using the PDN pin. The device is in power down (turned off) if PDN = VDD and in power up (turned on) if PDN = VSS. Fast startup is triggered automatically by the falling edge of PDN signal, i.e., controlling device from power down to power up. The VDD must be high before falling edge of PDN to guarantee proper operation of fast startup circuitry. Before power up the device should have been kept in power down state at least 50ms. This guarantees that the AGC capacitor voltage has been completely pulled to VDD during power down. The startup time without proper fast startup control can be over minute but with fast startup it is shortened typically to a few seconds.

Note 4: Optional Control for AGC On/Hold

AON control pin has internal pull up which turns AGC circuit on all the time if AON pin is left unconnected. Optionally AON control can be used to hold and release AGC circuit. Stepper motor drive of analog clock or watch can produce disturbing amount of noise which can shift the input amplifier gain to unoptimal level. This can be avoided by controlling AGC hold (AON=VSS) during stepper motor drive periods and releasing AGC (AON=VDD) when motors are not driven. The AGC should be in hold only during disturbances and kept on other time released since due to leakage the AGC voltage can change slowly even when in hold.

Note 5: Ferrite Antenna

The ferrite antenna converts the transmitted radio wave into a voltage signal. It has an important role in determining receiver performance. Recommended antenna impedance at resonance is around 100 kΩ.

Low antenna impedance corresponds to low noise but often also to small signal amplitude. On the other hand high antenna impedance corresponds to high noise but also large signal. The optimum performance where signal-to-noise ratio is at maximum is achieved in between.

The antenna should have also some selectivity for rejecting near signal band disturbances. This is determined by the antenna quality factor which should be approximately 100. Much higher quality factor antennas suffer from extensive tuning accuracy requirements and possible tuning drifts by the temperature.

Antenna impedance R_{ant} can be calculated using equation 1 where f_{res} , L , Q_{ant} and C are resonance frequency, coil inductance, antenna quality factor and antenna tuning capacitor respectively. Antenna quality factor Q_{ant} is defined by ratio of resonance frequency f_{res} and antenna bandwidth B (equation 2).

$$R_{ant} = 2\pi \cdot f_{res} \cdot L \cdot Q_{ant} = \frac{Q_{ant}}{2\pi \cdot f_{res} \cdot C} = \frac{1}{2\pi \cdot B \cdot C} \quad \text{Equation 1.}$$

$$Q_{ant} = \frac{f_{res}}{B} \quad \text{Equation 2.}$$

Table 4 on next page presents some antenna suppliers for time signal application.

TYPICAL APPLICATION (Continued)
Table 4. Antenna Suppliers and Antenna Types for Time Signal Application

Supplier	Antenna Type	Dimensions	Web Link
Micro Analog Systems Oy	A10X60-77.5K222PY A10X100-77.5K222PY A3.5X4X15-7.87MH A2X3X21-0.92MH A3.75X3.75X23.6-0.92MH	∅ 10 x 60 mm ∅ 10 x 100 mm 3.5 x 4 x 15 mm 2 x 3 x 21 mm 3.75x3.75x23 mm	http://www.mas-oy.com/en/products/radio-controlled-clock-rcc/antennas/
HR Electronic GmbH	60716 (60 kHz) 60708 (77.5 kHz)	∅ 10 x 60 mm	http://www.hrelectronic.com/
Hitachi Metals	AN-T702Sxx AN-T702Mxx AN-T702Lxx	19 x 5.5 x 6.3 mm 28 x 5 x 5 mm 50 x 5 x 5 mm	http://www.hitachi-metals.co.jp/e/prod/prod06/p06_12.html
Premo	RCA-SMD-77A (77.5 kHz) RCA-SMD-60A (60 kHz)	75 x 15 x 6.3 mm	http://www.grupopremo.com/
Sumida	ACL80A (40 kHz)	∅ 10 x 80 mm	www.sumida.co.jp/jeita/XJA021.pdf

Note 6: Time Signal Software's Pulse Width Recognition Limits

The typical output pulse width specifications are presented in the electrical characteristics section on page 3. Due to process variations the typical output pulse width can differ from these. Additionally the output pulse widths can vary even more depending on the receiving antenna signal strength versus noise and disturbance conditions. That is why it is important that the time signal decoding software has appropriate tolerance limits for managing the output pulse width variations successfully. The table 5 presents recommended software pulse width tolerance limits for recognizing pulses of different time signals.

Table 5. Recommended Software Pulse Width Recognition Limits for Different Time Signals

Parameter	Symbol	Min	Max	Unit
DCF77 Output Pulses	T _{100ms}	40	130	ms
	T _{200ms}	140	250	
MSF Output Pulses	T _{100ms}	50	160	ms
	T _{200ms}	170	270	
	T _{300ms}	280	380	
	T _{500ms}	400	600	
WWVB Output Pulses	T _{200ms}	100	300	ms
	T _{500ms}	400	600	
	T _{800ms}	700	900	
JJY60 Output Pulses	T _{200ms}	100	300	ms
	T _{500ms}	400	600	
	T _{800ms}	700	900	
JJY40 Output Pulses	T _{200ms}	100	300	ms
	T _{500ms}	400	600	
	T _{800ms}	700	900	

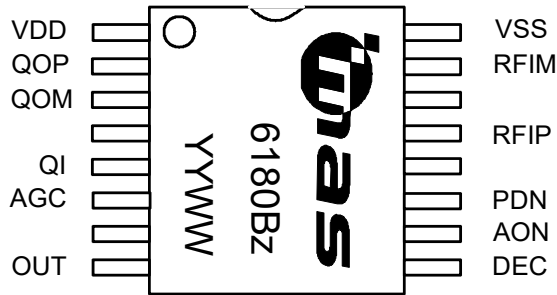
PIN CONFIGURATION & TOP MARKING FOR PLASTIC TSSOP-16 PACKAGE

Top Marking Definitions:
 z = Version Number
 YYWW = Year Week

PIN DESCRIPTION

Pin Name	Pin	Type	Function	Note
VDD	1	P	Positive Power Supply	
QOP	2	AO	Positive Quartz Filter Output for Crystal	
QOM	3	AO	Negative Quartz Filter Output for External Compensation Capacitor or Second Crystal	1
	4	NC		2
QI	5	AI	Quartz Filter Input for Crystal and External Compensation Capacitor	
AGC	6	AO	AGC Capacitor	
	7	NC		2
OUT	8	DO	Receiver Output	3
DEC	9	AO	Demodulator Capacitor	
AON	10	DI	AGC On Control	4
PDN	11	DI	Power Down Input	5
	12	NC		2
RFIP	13	AI	Positive Receiver Input	6
	14	NC		2
RFIM	15	AI	Negative Receiver Input	6
VSS	16	G	Power Supply Ground	

A = Analog, D = Digital, P = Power, G = Ground, I = Input, O = Output, NC = Not Connected

Notes:

- External crystal compensation capacitor pin QOM is connected only in MAS6180B5 version. It is left unconnected in MAS6180B1 version which has internal compensation capacitor.
- Pin 4 between QOM and QI must be connected to IC's filtered VDD (pin 1) to eliminate TSSOP package lead frame parasitic capacitances disturbing the crystal filter performance and minimizing noise coupling. All other NC (Not Connected) type pins are recommended to be connected to VSS.
- OUT = VSS when carrier amplitude at maximum; OUT = VDD when carrier amplitude is reduced (modulated)
 - the output is a current source/sink with $|I_{out}| > 5 \mu A$
 - at power down the output is pulled to VSS (pull down switch)
- AON = VSS means AGC off (hold current gain level); AON = VDD means AGC on (working)
 - Internal pull-up with current $< 1 \mu A$ which is switched off at power down
- PDN = VSS means receiver on; PDN = VDD means receiver off
 - Fast start-up is triggered when the receiver is after power down (PDN=VDD) controlled to power up (PDN=VSS) i.e. at the falling edge of PDN signal.
- Receiver inputs RFIP and RFIM have both 1.4 M Ω biasing resistors towards VDD

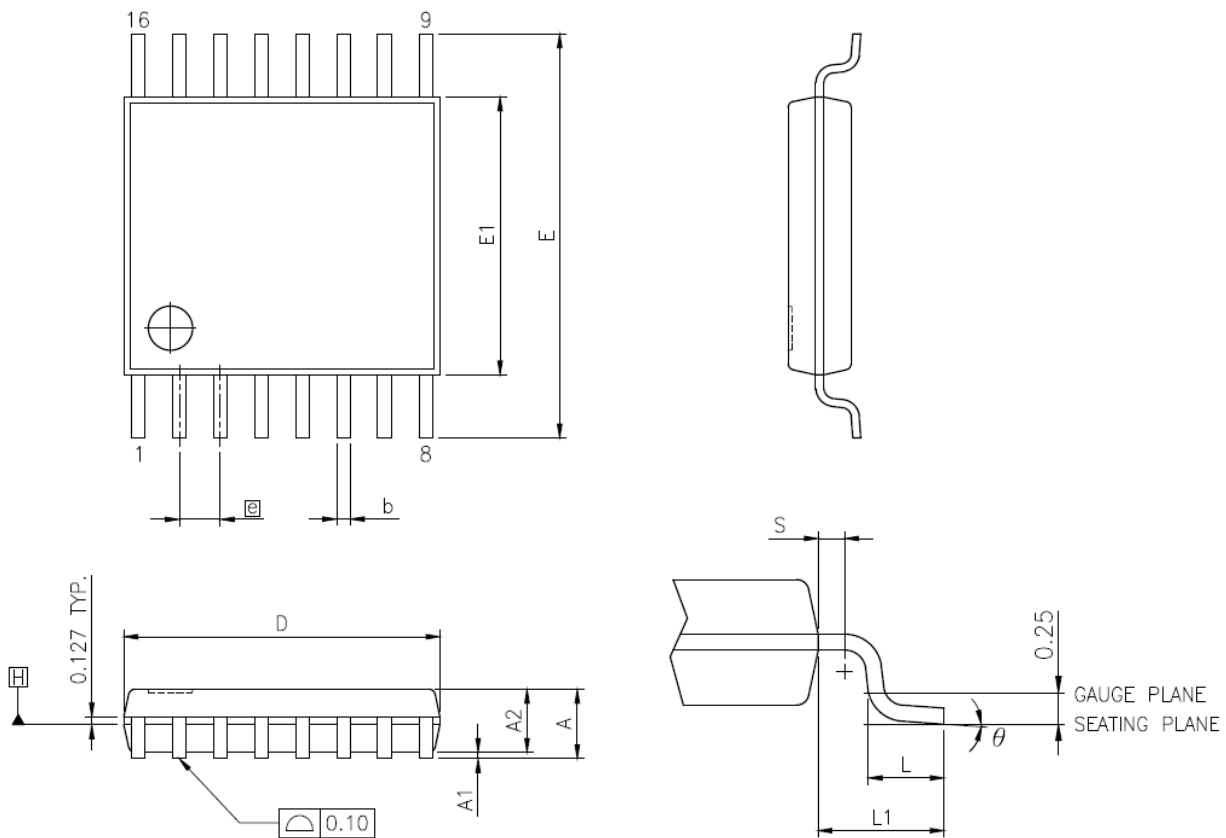
PACKAGE (TSSOP-16) OUTLINES

Dimension	Min	Nom	Max	Unit
A			1.2	mm
A1	0.05		0.15	mm
A2	0.80	1.00	1.05	mm
b	0.19		0.30	mm
D	4.90	5.00	5.10	mm
E1	4.30	4.40	4.50	mm
E		6.40 BSC		mm
e		0.65 BSC		mm
L1		1.00 REF		mm
L	0.45	0.60	0.75	mm
S	0.20			mm
θ	0		8	$^{\circ}$

Dimensions do not include mold flash, protrusions, or gate burrs.
 All dimensions are in accordance with JEDEC standard MO-153.

SOLDERING INFORMATION

◆ For Pb-Free, RoHS Compliant TSSOP-16

Resistance to Soldering Heat	According to RSH test IEC 68-2-58/20
Maximum Temperature	260°C
Maximum Number of Reflow Cycles	3
Reflow profile	Thermal profile parameters stated in IPC/JEDEC J-STD-020 should not be exceeded. http://www.jedec.org
Seating Plane Co-planarity	max 0.08 mm
Lead Finish	Solder plate 7.62 - 25.4 μm, material Matte Tin

EMBOSED TAPE SPECIFICATIONS

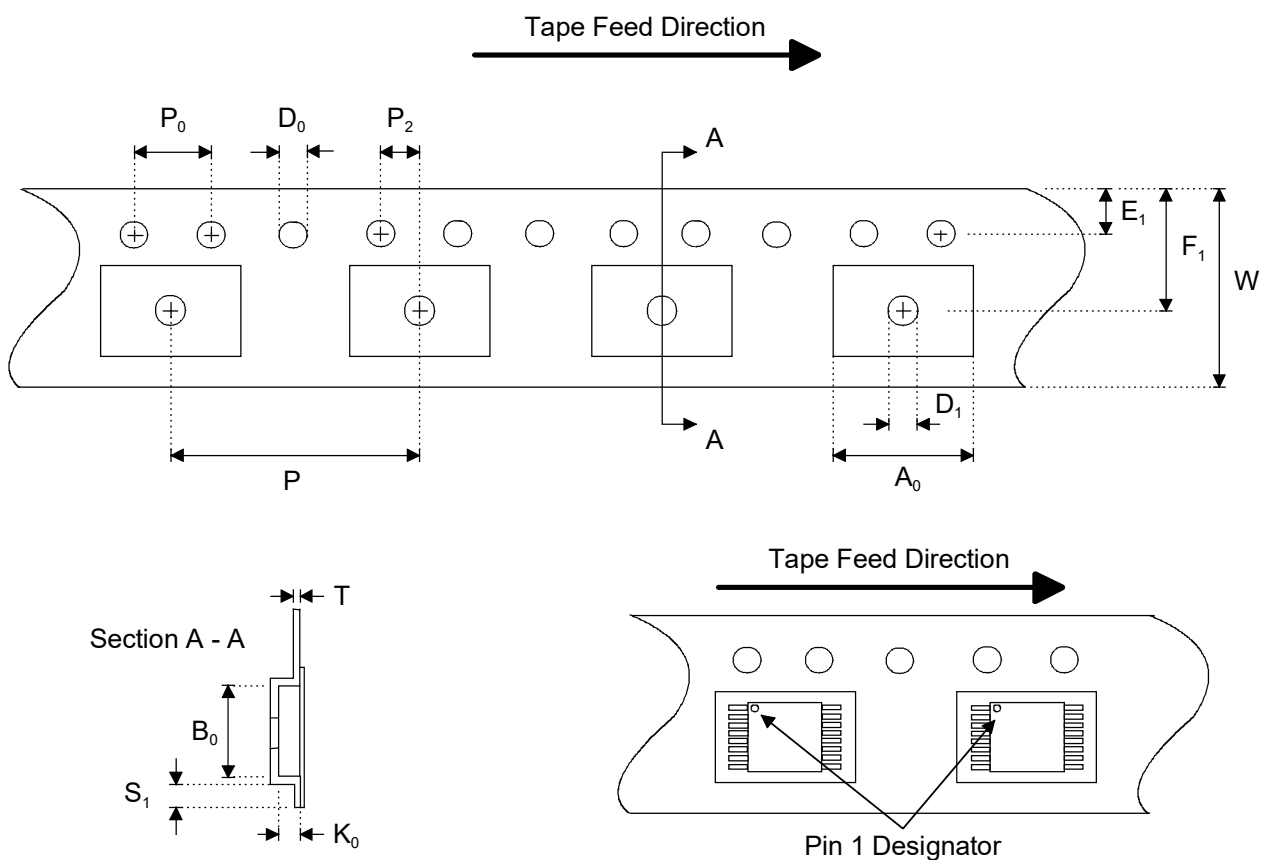

Dimension	Min	Max	Unit
A ₀	6.50	6.70	mm
B ₀	5.20	5.40	mm
D ₀	1.50 +0.10 / -0.00		mm
D ₁	1.50		mm
E ₁	1.65	1.85	mm
F ₁	7.20	7.30	mm
K ₀	1.20	1.40	mm
P	11.90	12.10	mm
P ₀	4.0		mm
P ₂	1.95	2.05	mm
S ₁	0.6		mm
T	0.25	0.35	mm
W	11.70	12.30	mm

REEL SPECIFICATIONS

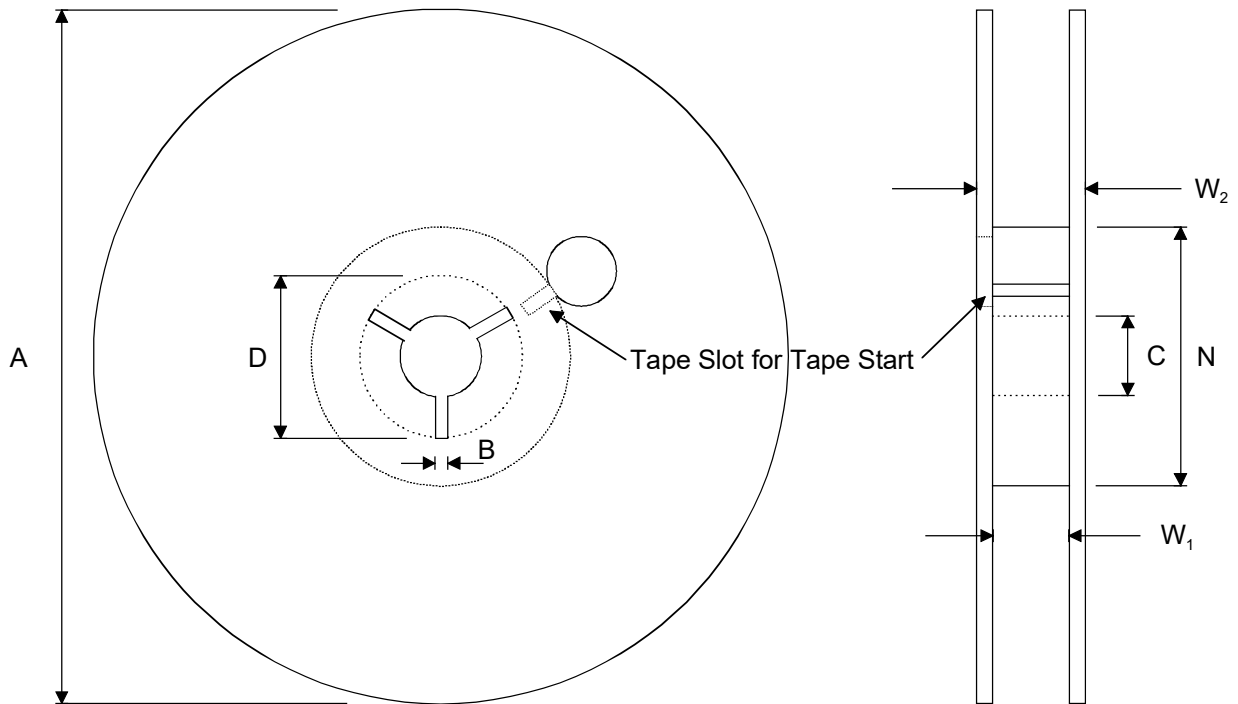

2000 Components on Each Reel

Reel Material: Conductive, Plastic Antistatic or Static Dissipative

Carrier Tape Material: Conductive

Cover Tape Material: Static Dissipative

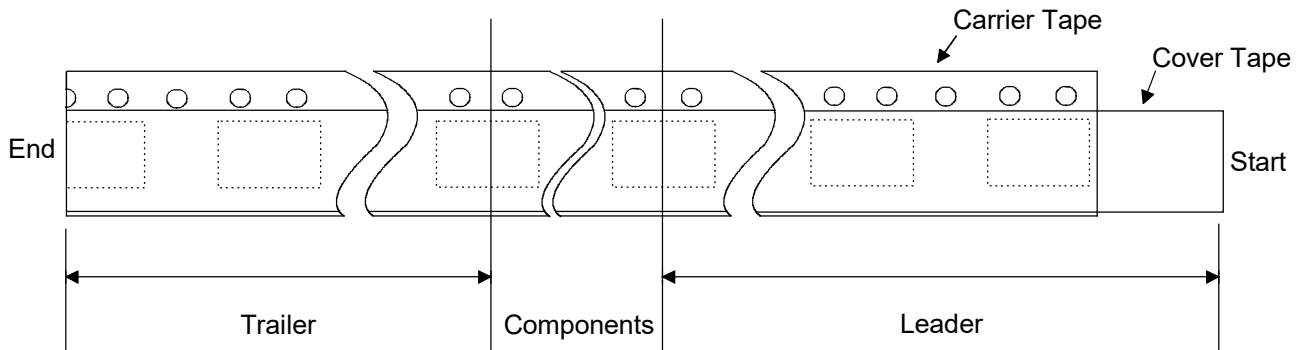

Dimension	Min	Max	Unit
A		330	mm
B	1.5		mm
C	12.80	13.50	mm
D	20.2		mm
N	50		mm
W_1 (measured at hub)	12.4	14.4	mm
W_2 (measured at hub)		18.4	mm
Trailer	160		mm
Leader	390, of which minimum 160 mm of empty carrier tape sealed with cover tape		mm
Weight		1500	g

ORDERING INFORMATION

Product Code	Product	Description	Capacitance Option
MAS6180B1TC00	Single Band AM-Receiver IC with Differential Input	Tested wafer with inking, diameter 8", thickness 395 $\mu\text{m} \pm 5\%$.	$C_C = 0.75 \text{ pF}$
MAS6180B1TC13	Single Band AM-Receiver IC with Differential Input	Tested non-inked wafer with wafer map, diameter 8", thickness 395 $\mu\text{m} \pm 5\%$.	$C_C = 0.75 \text{ pF}$
MAS6180B5TC00	Single Band AM-Receiver IC with Differential Input	Tested wafer with inking, diameter 8", thickness 395 $\mu\text{m} \pm 5\%$.	External compensation capacitor
MAS6180B5TC13	Single Band AM-Receiver IC with Differential Input	Tested non-inked wafer with wafer map, diameter 8", thickness 395 $\mu\text{m} \pm 5\%$.	External compensation capacitor
MAS6180B1UC06	Single Band AM-Receiver IC with Differential Input	TSSOP-16, Pb-free, RoHS compliant, Tape & Reel	$C_C = 0.75 \text{ pF}$

Contact Micro Analog Systems Oy for other wafer thickness options.

◆ The formation of product code

An example for MAS6180B1TC00:

MAS6180	B	1	TC	00
Product name	Design version	Capacitance option: $C_C = 0.75 \text{ pF}$	Package type: TC = 400 μm thick tested wafer	Delivery format: 00 = wafer with inking 05 = dies on tray 06 = tape & reel 08 = in tube 13 = non-inked wafer with wafer map

LOCAL DISTRIBUTOR

MICRO ANALOG SYSTEMS OY CONTACTS

Micro Analog Systems Oy Kutomotie 16 FI-0038 Helsinki, FINLAND	Tel. +358 10 835 1100 http://www.mas-oy.com
--	--

NOTICE

Micro Analog Systems Oy reserves the right to make changes to the products contained in this data sheet in order to improve the design or performance and to supply the best possible products. Micro Analog Systems Oy assumes no responsibility for the use of any circuits shown in this data sheet, conveys no license under any patent or other rights unless otherwise specified in this data sheet, and makes no claim that the circuits are free from patent infringement. Applications for any devices shown in this data sheet are for illustration only and Micro Analog Systems Oy makes no claim or warranty that such applications will be suitable for the use specified without further testing or modification.