

MAS9275

IC FOR 10.00 – 36.00 MHz VCXO

- Square Wave (CMOS) Output
- Very Low Phase Noise
- Low Power
- Wide Supply Voltage Range
- Very High Level of Integration
- Low Cost

DESCRIPTION

MAS9275 is a VCXO IC to be used in making VCXO modules for telecommunication and other

applications. To build a complete VCXO only one additional component, a crystal, is needed.

FEATURES

- Very small size
- Minimal current consumption
- Wide operating temperature range
- Phase noise <-130 dBc/Hz at 1 kHz offset
- Square wave (CMOS) output

APPLICATIONS

- VCXO for telecommunications systems
- VCXO for set-top boxes
- VCXO for MPEG

BLOCK DIAGRAM

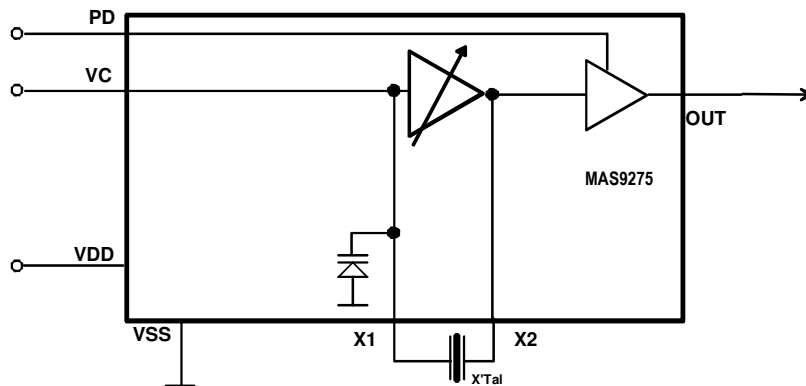

PIN DESCRIPTION

Pin Description	Symbol	x-coordinate	y-coordinate	Note
Crystal/Varactor Oscillator Input	X1	209	161	
Voltage Control Input	VC	425	165	
Power Supply Ground	VSS	600	175	
Buffer Output	OUT	1029	1030	
Power Supply Voltage	VDD	841	1016	
Tri State	PD	379	1028	
Crystal Oscillator Output	X2	197	1030	

Note: Because the substrate of the die is internally connected to GND, the die has to be connected to GND or left floating. Please make sure that GND is the first pad to be bonded. Pick-and-place and all component assembly are recommended to be performed in ESD protected area.

Note: Pad coordinates are measured from the left bottom corner of the chip to the center of the pads. The coordinates may vary depending on sawing width and location, however, distances between pads are accurate.

ABSOLUTE MAXIMUM RATINGS

Parameter	Symbol	Conditions	Min	Max	Unit	Note
Supply Voltage	$V_{DD} - V_{SS}$		-0.3	6.0	V	
Input Pin Voltage			$V_{SS} - 0.3$	$V_{DD} + 0.3$	V	
Power Dissipation	P_{MAX}			100	mW	
Storage Temperature	T_{ST}		-55	150	°C	
ESD Rating		HBM		2	kV	

RECOMMENDED OPERATION CONDITIONS

Parameter	Symbol	Conditions	Min	Typ	Max	Unit	Note
Supply Voltage	V_{DD}		2.5	2.8	5.5	V	1)
Supply Current	I_{DD}	$V_{DD} = 2.8\text{ V}$		2.3		mA	
Operating Temperature	T_{OP}		-40		+85	°C	
Voltage Control Line Impedance	V_{CIMP}	MAS9275A, MAS9275B		1		MΩ	
Crystal Pulling Sensitivity	S			30		ppm/pF	
Crystal Load Capacitance	C_L	$V_C = 1.65\text{ V}$ MAS9275A1 MAS9275B2 MAS9275B3 MAS9275C2 MAS9275C3 MAS9275C4		8 10 10.5 10 10.5 10.5		pF	2) 2) 2) 2)

Note 1: It is recommend to connect a 1 nF capacitor to the VDD pin (either in a module or in an end application).

Note 2: Crystal Load Capacitance is typically 8.2 pF, when $V_C = 2.5\text{ V}$.

ELECTRICAL CHARACTERISTICS

(recommended operation conditions)

Parameter	Symbol	Min	Typ	Max	Unit	Note
Frequency Range	f_o	10.00		36.00	MHz	1)
Voltage Control Range	V_C	0		VDD	V	
Voltage Control Sensitivity	V_{CSSENS}		100		ppm/V	2)
Output Voltage (10 pF, VDD 2.7 V)	V_{out}		2.3		Vpp	
Output Voltage (10 pF, VDD 5.0 V)	V_{out}		4.5		Vpp	
Rise and Fall Time (10 - 50 pF)				10	ns	
Output Symmetry			40-60		%	
Startup Time	T_{START}		2		ms	
Tri State Output Buffer ON State OFF State	PD	0 1.6		0.55 VDD	V	3)
Tri State Output Buffer ON State OFF State	PD	1.6 0		VDD 0.55	V	4)

Note 1: An $R_S < 20 \Omega$ crystal provides 36 MHz maximum frequency. With an $R_S = 70 \Omega$ crystal the maximum frequency is typically 20 MHz.

Note 2: VC sensitivity value depends on the crystal used. With a 30 ppm/pF crystal typical values are: A1 > 100 ppm/V, B2 > 75 ppm/V, B3 > 60 ppm/V, C2 > 75 ppm/V, C3 > 60 ppm/V, C4 > 55 ppm/V.

Note 3: MAS9275A, MAS9275B

Note 4: MAS9275C

Note 5: If the Tri State Output Buffer is floating (i.e., PD pin not connected), the oscillator is ON in all models (MAS9275A, -B and -C)

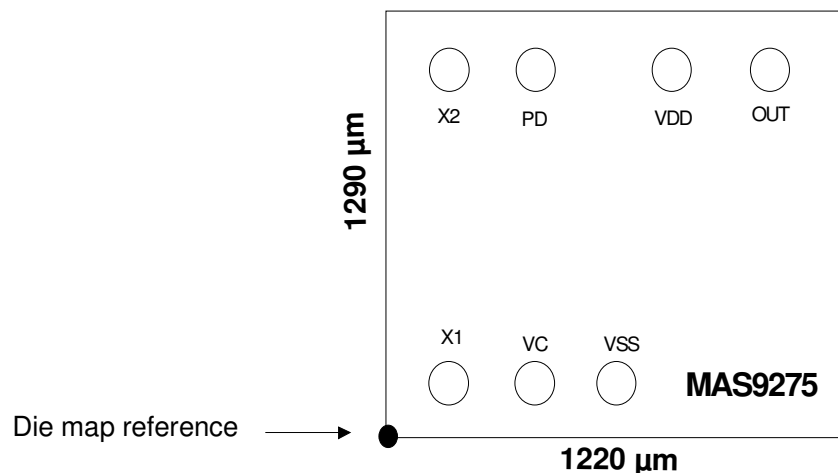
IC OUTLINES

Note 1: MAS9275 pads are round with 80 μm diameter at opening.

Note 2: Die map reference is the actual left bottom corner of the sawn chip.

EXTERNAL COMPONENT SELECTION

MAS9275 requires a minimum number of external components for proper operation.

Quartz Crystal

The MAS9275 VCXO function consists of the external crystal and the integrated VCXO oscillator circuit. To assure the best system performance (frequency pull range) and reliability, a crystal device with the recommended parameters (shown below) must be used, and the layout guidelines in the following section must be followed. The frequency of oscillation of a quartz crystal is determined by its “cut” and by the load capacitors

connected to it. MAS9275 incorporates on-chip variable load capacitors that “pull” (change) the frequency of the crystal. The crystal specified for use with the MAS9275B2 is designed to have zero frequency error when the total of on-chip + stray capacitance is 10 pF (See Note 1 on page 2 for other capacitance options).

Recommended Crystal Parameters:

Initial Accuracy at 25 °C ±20 ppm

Temperature Stability ±30 ppm

Crystal Load Capacitance 10 pf (See Note1 below)

Crystal Shunt Capacitance, C0 2 pF Typical

C0/C1 Ratio Typical ≤ 300

Equivalent Series Resistance 20 Ω max. Crystals with higher ESR can be used if frequency is < 36 MHz. See Note 2 under Electrical Characteristics on Page 3.

The external crystal must be connected as close to the chip as possible and should be on the same side of the PCB as the MAS9275. There should be no vias between the crystal pins and the X1 and X2 device pins. There should be no signal traces underneath or close to the crystal.

Note 1. If the crystal with a load other than the nominal Crystal Load Capacitance as defined in Recommended Operation Conditions on page 2 is used with MAS9275, the crystal has to have frequency offset in order to have the nominal frequency at VC = 1.65 V or at VC = 2.5 V. Please see table below for offset frequencies vs. crystal load. (Values are for a typical crystal with S = 30 ppm/pF.)

Crystal frequency		19.68	19.68	27.00	40.00	MHz
Crystal Load		8	10	12.5	16	pF
	V _C voltage	Offset in crystal frequency				
A1	1.65 V	+0	-60	-150	-240	ppm
B2, C2	1.65 V	+60	0	-75	-180	ppm
B3, C3, C4	1.65 V	+85	+25	-50	-155	ppm
B3, C3, C4	2.5 V	+30	-30	-105	-210	ppm

Note: 19.68 MHz crystal with 10 pF load capacitance used with MAS9275B2 or C2 may not require frequency offset because of small deviation

For example:

For application using MAS9275B2 or C2 with nominal frequency of 27.00 MHz a crystal with 12.5 pF load has to have a frequency of $27.00 \text{ MHz} + ((27.00 \text{ MHz}/10^6) \times (-90)) = 26.99757 \text{ MHz}$.

MODULATION RESPONSE

Figure 2. Modulation response (gain).

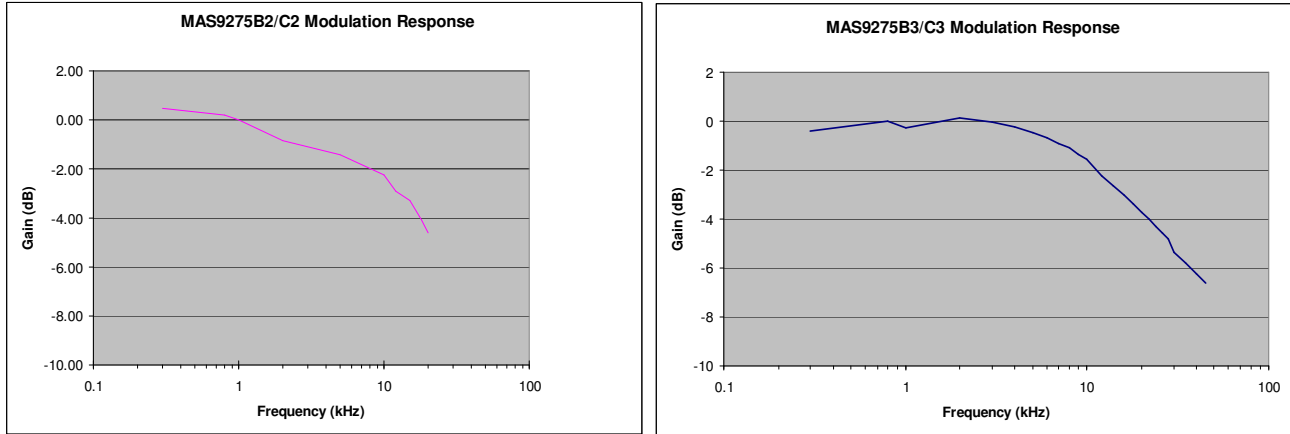

TYPICAL APPLICATION

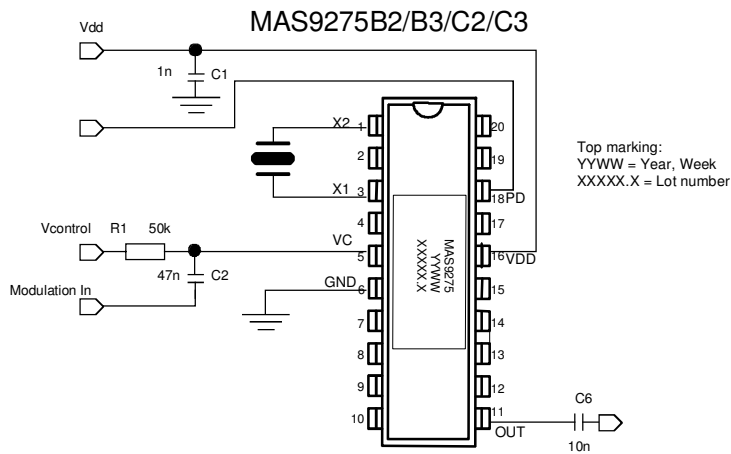

SAMPLES IN SB20 DIL PACKAGE

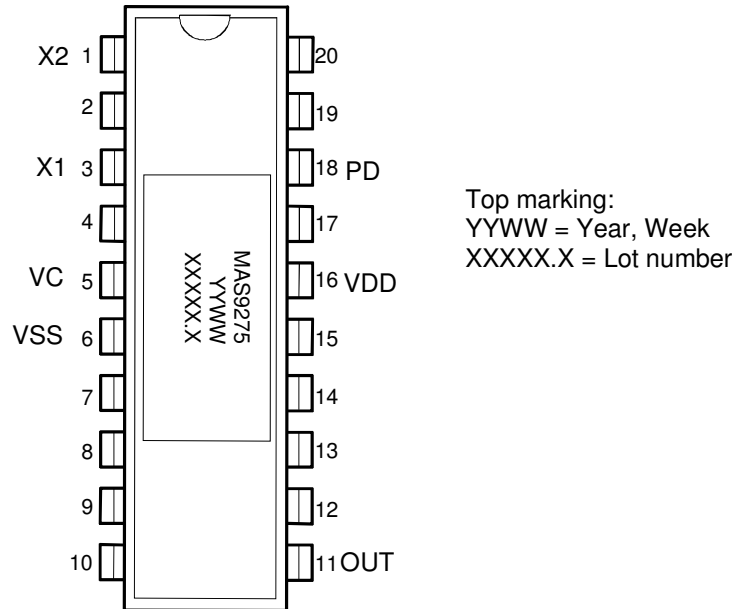

DEVICE OUTLINE CONFIGURATION

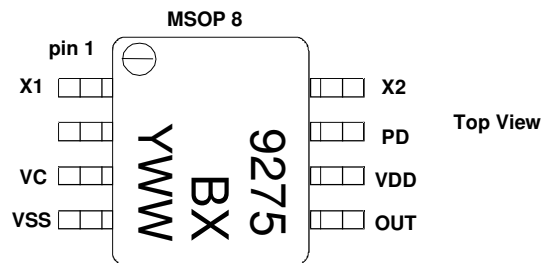

B = product version
X = MAS internal code
Y = year
WW = week

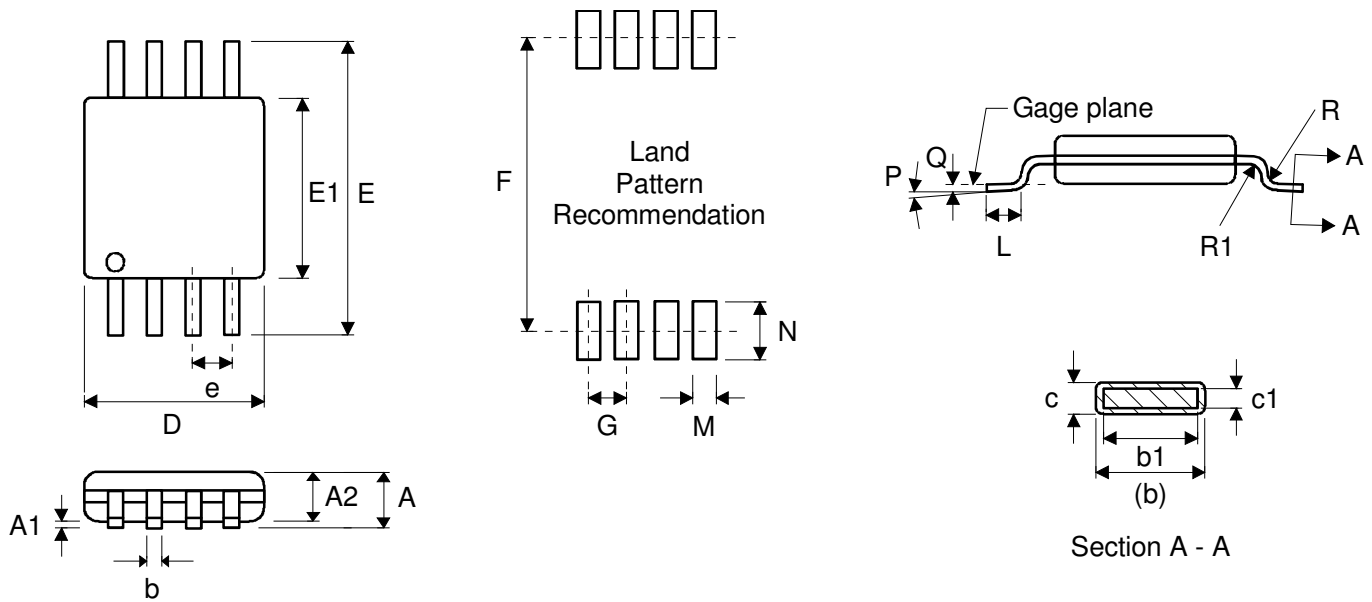
PACKAGE (MSOP-8) OUTLINE

Symbol	Min	Nom	Max	Unit
A			1.10	mm
A1	0		0.15	mm
A2	0.75	0.85	0.95	mm
b	0.22		0.38	mm
b1	0.22	0.30	0.33	mm
c	0.08		0.23	mm
c1	0.08		0.18	mm
D		3.00 BSC		mm
E		4.90 BSC		mm
E1		3.00 BSC		mm
e		0.65 BSC		mm
F		4.8		mm
G		0.65		mm
L	0.40	0.60	0.80	mm
(Terminal length for soldering)				
M		0.41		mm
N		1.02		mm
P	0°		8°	
Q		0.25 BSC		mm
R	0.07			mm
R1	0.07			mm

Dimensions do not include mold or interlead flash, protrusions or gate burrs.
 All measurement according to JEDEC standard MO-187.

SOLDERING INFORMATION

Resistance to Soldering Heat	According to RSH test IEC 68-2-58/20 2*220°C
Maximum Temperature	240°C
Maximum Number of Reflow Cycles	2
Reflow profile	Thermal profile parameters stated in JESD22-A113 should not be exceeded. http://www.jedec.org
Seating Plane Co-planarity	max 0.08 mm
Lead Finish	Solder plate 7.62 - 25.4 μm, material Sn 85% Pb 15%

EMBOSSED TAPE SPECIFICATIONS

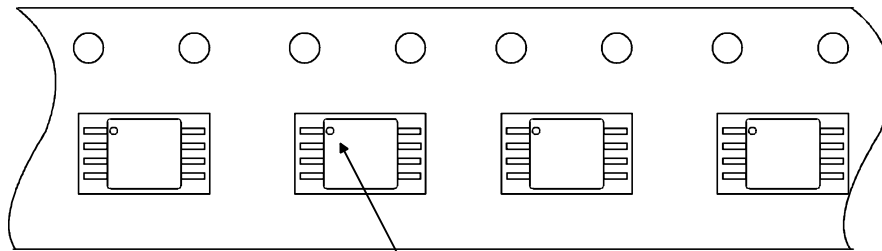
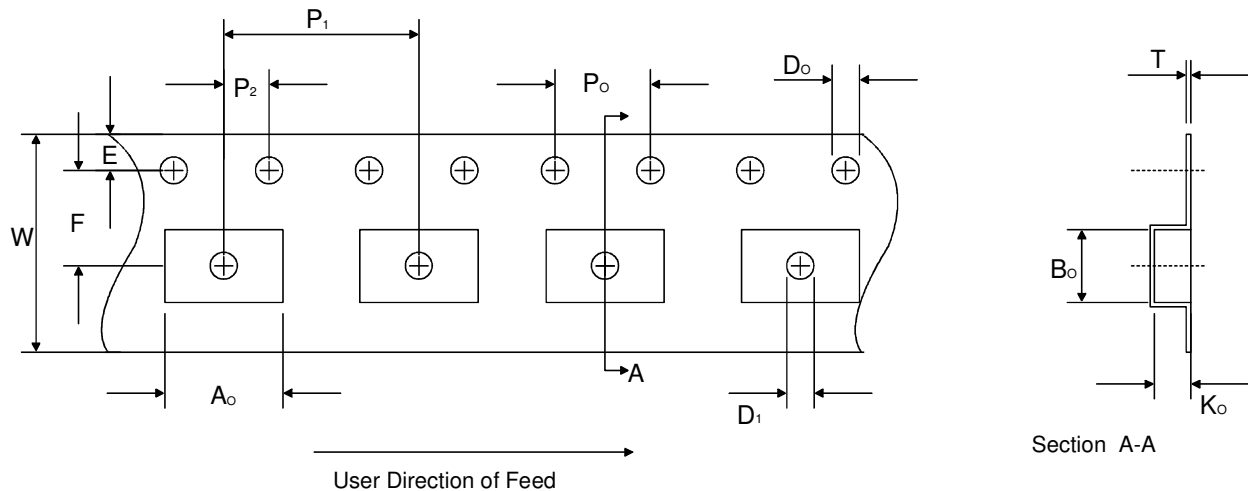

Pin 1 Designator

Dimension	Min/Max	Unit
A_o	5.00 ±0.10	mm
B_o	3.20 ±0.10	mm
D_o	1.50 +0.1/-0.0	mm
D_1	1.50 min	mm
E	1.75	mm
F	5.50 ±0.05	mm
K_o	1.45 ±0.10	mm
P_o	4.0	mm
P_1	8.0 ±0.10	mm
P_2	2.0 ±0.05	mm
T	0.3 ±0.05	mm
W	12.00 +0.30/-0.10	mm

REEL SPECIFICATIONS

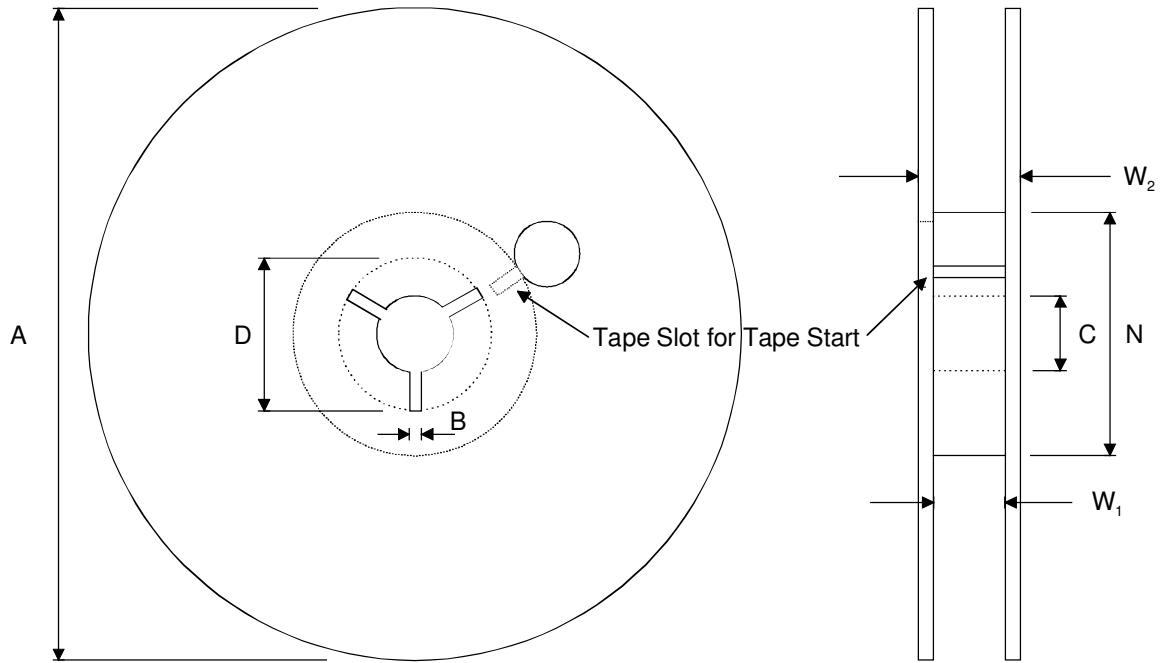

5000 Components on Each Reel

Reel Material: Conductive, Plastic Antistatic or Static Dissipative
Carrier Tape Material: Conductive
Cover Tape Material: Static Dissipative

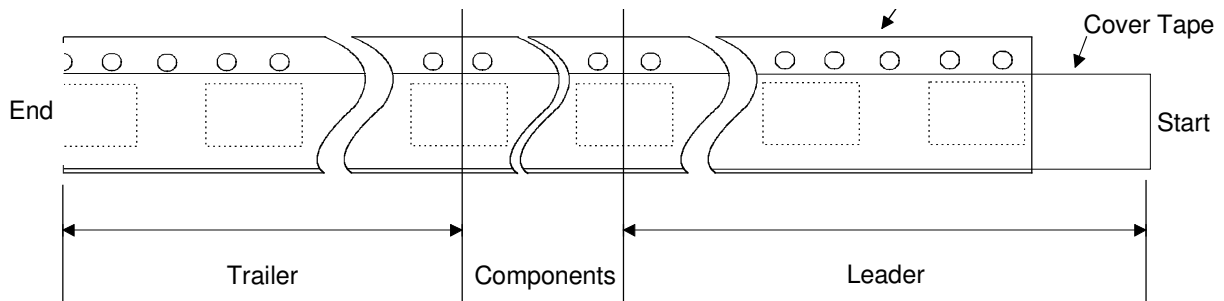

Dimension	Min	Max	Unit
A		330	mm
B	1.5		mm
C	12.80	13.50	mm
D	20.2		mm
N	50		mm
W_1 (measured at hub)	12.4	14.4	mm
W_2 (measured at hub)		18.4	mm
Trailer	160		mm
Leader	390, of which minimum 160 mm of empty carrier tape sealed with cover tape		mm
Weight		1500	g

ORDERING INFORMATION

Product Code	Product	Typical Vc-Sensitivity (with 30 ppm/pF crystal)	Package
MAS9275A1TG00	IC FOR 2.8 V VCXO Negative PD logic	> 100 ppm/V	EWS tested wafers 215 µm
MAS9275A1SM06	IC FOR 2.8 V VCXO Negative PD logic	> 100 ppm/V	MSOP-8, T&R/5000 pcs/r.
MAS9275B2TG00	IC FOR 3.3 V VCXO Negative PD logic	> 75 ppm/V	EWS tested wafers 215 µm
MAS9275B2SM06	IC FOR 3.3 V VCXO Negative PD logic	> 75 ppm/V	MSOP-8, T&R/5000 pcs/r.
MAS9275B3TG00	IC FOR 5.0 V VCXO Negative PD logic	> 60 ppm/V	EWS tested wafers 215 µm
MAS9275B3SM06	IC FOR 5.0 V VCXO Negative PD logic	> 60 ppm/V	MSOP-8, T&R/5000 pcs/r.
MAS9275C2TG00	IC FOR 3.3 V VCXO Positive PD logic	> 75 ppm/V	EWS tested wafers 215 µm
MAS9275C2SM06	IC FOR 3.3 V VCXO Positive PD logic	> 75 ppm/V	MSOP-8, T&R/5000 pcs/r.
MAS9275C3TG00	IC FOR 5.0 V VCXO Positive PD logic	> 60 ppm/V	EWS tested wafers 215 µm
MAS9275C3SM06	IC FOR 5.0 V VCXO Positive PD logic	> 60 ppm/V	MSOP-8, T&R/5000 pcs/r.
MAS9275C4TG00	IC FOR 5.0 V VCXO Positive PD logic	> 55 ppm/V	EWS tested wafers 215 µm
MAS9275C4SM06	IC FOR 5.0 V VCXO Positive PD logic	> 55 ppm/V	MSOP-8, T&R/5000 pcs/r.

Contact Micro Analog Systems Oy for other wafer thickness options.

LOCAL DISTRIBUTOR

--

MICRO ANALOG SYSTEMS OY CONTACTS

Micro Analog Systems Oy Kamreerintie 2, P.O. Box 51 FIN-02771 Espoo, FINLAND	Tel. +358 9 80 521 Fax +358 9 805 3213 http://www.mas-oy.com
--	--

NOTICE

Micro Analog Systems Oy reserves the right to make changes to the products contained in this data sheet in order to improve the design or performance and to supply the best possible products. Micro Analog Systems Oy assumes no responsibility for the use of any circuits shown in this data sheet, conveys no license under any patent or other rights unless otherwise specified in this data sheet, and makes no claim that the circuits are free from patent infringement. Applications for any devices shown in this data sheet are for illustration only and Micro Analog Systems Oy makes no claim or warranty that such applications will be suitable for the use specified without further testing or modification.