

MAS6285

IC FOR XO TRIMMING

- Very Low Power
- Wide Trimming Range
- Wide Supply Voltage Range
- Very High Level of Integration
- Electrically Trimmable
- Low Cost

DESCRIPTION

MAS6285 is capacitive digital to analog converter integrated circuit well suited to make initial offset trimming of the crystal oscillator. The trimming is

done by a serial bus and the calibration information is stored in an internal PROM.

FEATURES

- IC for Crystal oscillator offset trimming
- Very small size
- Minimum current draw
- Wide operating temperature range

APPLICATIONS

- High Frequency VCXOs
- OCXOs
- All Crystal Oscillators

BLOCK DIAGRAM

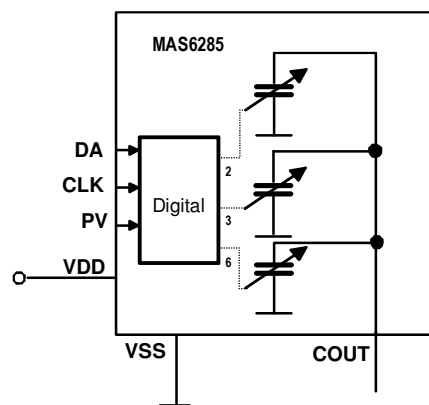

Figure 1. Block diagram of MAS6285.

PIN DESCRIPTION

Pin Description	Symbol	x-coordinate	y-coordinate	Note
Serial Bus Data Input	DA	150	141	
Serial Bus Clock Input	CLK	369	141	
Programming Input	PV	593	140	
Power Supply Voltage	VDD	150	689	
Power Supply Ground	VSS	369	689	
CDAC Output	COUT	593	689	

Note: Because the substrate of the die is internally connected to VSS, the die has to be connected to VSS or left floating. Please make sure that VSS is the first pad to be bonded. Pick-and-place and all component assembly are recommended to be performed in ESD protected area.

Note: Pad coordinates measured from the left bottom corner of the chip to the center of the pads. The coordinates may vary depending on sawing width and location, however, distances between pads are accurate.

ABSOLUTE MAXIMUM RATINGS

Parameter	Symbol	Min	Max	Unit	Note
Supply Voltage	$V_{DD} - V_{SS}$	-0.3	6.0	V	
Input Voltage	V_{IN}	$V_{SS} - 0.3$	$V_{DD} + 0.3$	V	1)
Power Dissipation (max)	P_{MAX}		100	mW	
Storage Temperature	T_{ST}	-55	150	°C	
Latch-Up Current Limit	I_{LUT}	±100		mA	

Note: Stresses beyond the values listed may cause a permanent damage to the device. The device may not operate under these conditions, but it will not be destroyed.

Note: This is a CMOS device and therefore it should be handled carefully to avoid any damage by static voltages (ESD).

Note 1: Not valid for programming pin PV

RECOMMENDED OPERATION CONDITIONS

Parameter	Symbol	Conditions	Min	Typ	Max	Unit
Supply Voltage	V_{DD}		2.5	2.8	5.5	V
Operating Temperature	T_{OP}		-40		+85	°C

ELECTRICAL CHARACTERISTICS

(recommended operation conditions)

Parameter	Symbol	Min	Typ	Max	Unit	Note
Operating Frequency	f_{OP}			200	MHz	
Capacitance Range	C_{OUT}	3.3		34.3	pF	1)
Supply Current	I_{CC}	0.3		10	µA	2)

Note 1: Capacitance values are typical and may vary ± 25% due to the IC process variation. Capacitance range guaranteed by design.

Note 2: Minimum supply current is drawn when all bits are programmed as “0”. Maximum supply current is drawn when all bits are left unprogrammed “1”.

IC OUTLINES

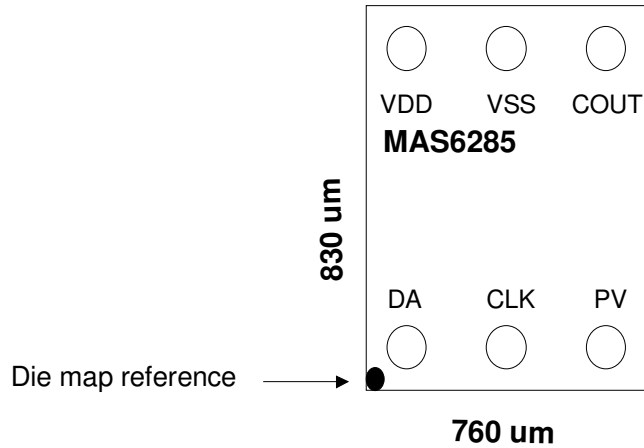

Figure 2. IC outline of MAS6285.

Note 1: MAS6285 pads are round with 80 μm diameter at opening.

Note 2: Pins PV, CLK and DA must not be connected in XO module end-user application.

APPLICATION

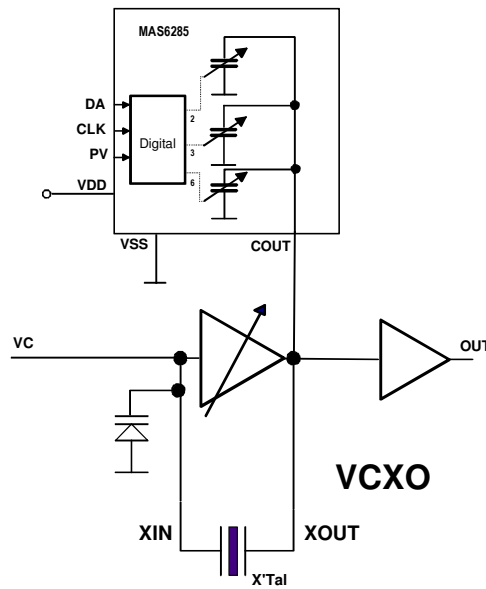
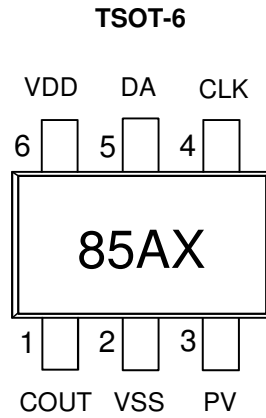

Figure 3. Typical application for MAS6285.

PIN CONFIGURATION (TSOT-6)



85AX = Product version (MAS6285AX, where x = letter or number)

Figure 4. TSOT-6 package.

PIN DESCRIPTION (TSOT-6)

Pin Name	Pin Number in TSOT-6	Type	Function
COUT	1	O	CDAC Output with Bias Option
VSS	2	G	Power Supply Ground
PV	3	I	Programming Input
CLK	4	I	Serial Bus Clock Input
DA	5	I	Serial Bus Data Input
VDD	6	P	Power Supply Voltage

G = Ground, I = Input, O = Output, P = Power

PIN CONFIGURATION (QFN-6)

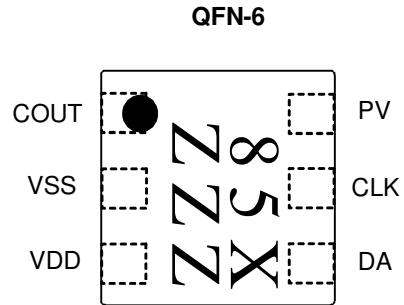

85X = Product version (MAS6285X, where X = letter or number)
ZZZ = MAS lot number (3 last digit)

Figure 5. QFN-6 package.

PIN DESCRIPTION (QFN-6)

Pin Name	Pin Number in TSOT-6	Type	Function
COUT	1	O	CDAC Output with Bias Option
VSS	2	G	Power Supply Ground
VDD	3	P	Power Supply Voltage
DA	4	I	Serial Bus Data Input
CLK	5	I	Serial Bus Clock Input
PV	6	I	Programming Input
G = Ground, I = Input, O = Output, P = Power			
Exposed pad* can be connected to ground or left floating * see package outline information on page 8			

PACKAGE OUTLINE (TSOT-6)

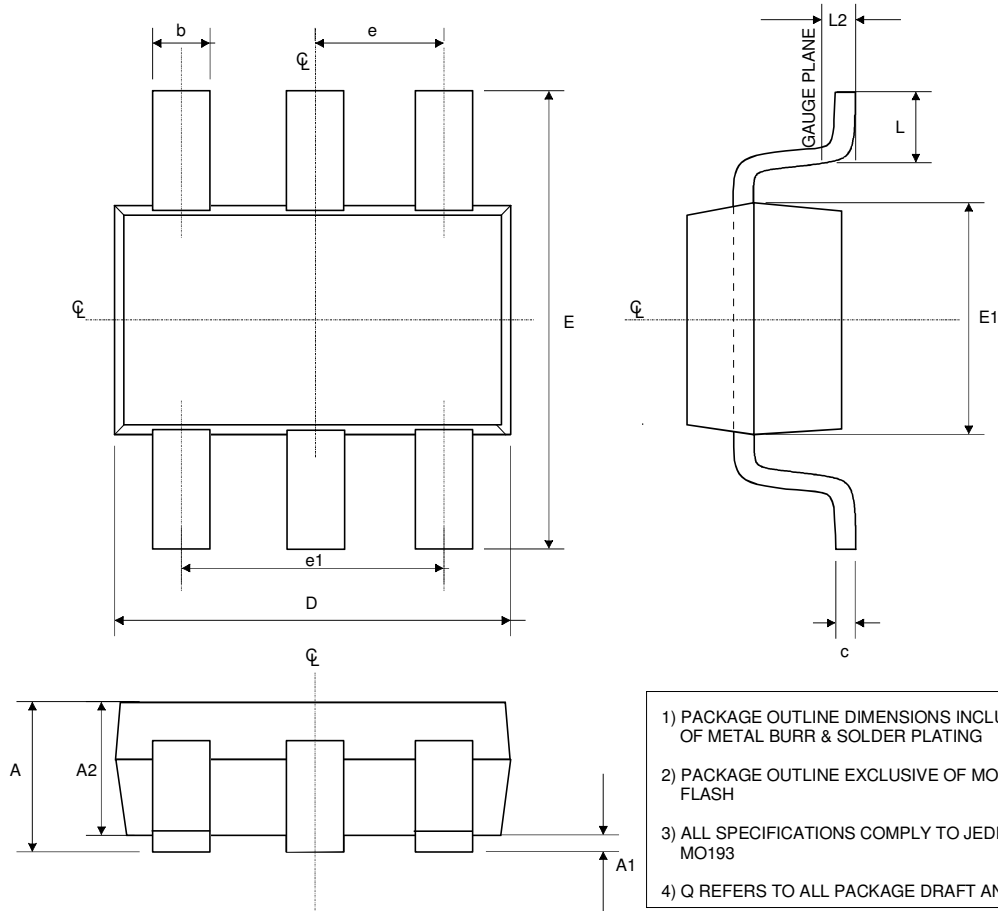

Symbol	Min	Nom	Max	Unit
A	--	--	1.00	mm
A1	0.01	0.05	0.10	mm
A2	0.84	0.87	0.90	mm
b	0.30	--	0.45	mm
c	0.12	0.127	0.20	mm
D		2.90BSC		mm
E		2.80BSC		mm
E1		1.60BSC		mm
e		0.95BSC		mm
e1		1.90BSC		mm
L	0.30	0.40	0.50	mm
L2		0.25BSC		mm
Q	4°	10°	12°	

SOLDERING INFORMATION (TSOT-6)

◆ For Lead-Free / RoHS Compliant Green TSOT-6

Resistance to Soldering Heat	According to RSH test IEC 68-2-58/20
Maximum Temperature	260°C
Maximum Number of Reflow Cycles	3
Reflow profile	Thermal profile parameters stated in JESD22-A113 should not be exceeded. http://www.jedec.org
Seating Plane Co-planarity	max 0.08 mm
Lead Finish	Solder plate 7.62 - 25.4 µm, material Matte Tin

TAPE & REEL SPECIFICATIONS (TSOT-6)

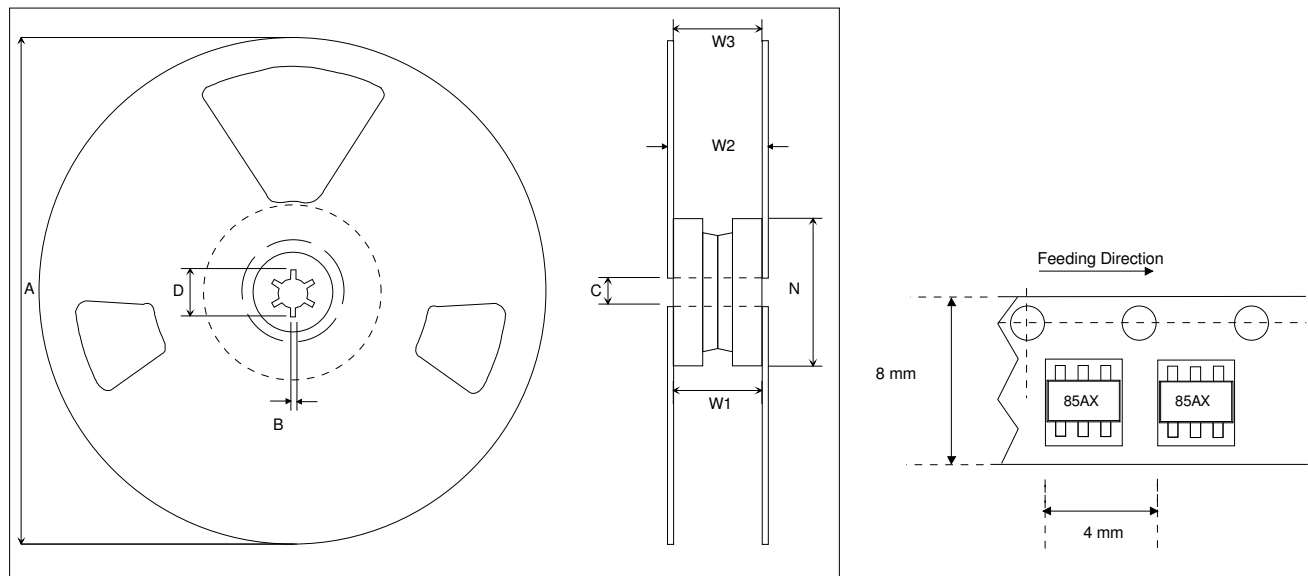

Other Dimensions according to EIA-481 Standard

3000 Components on Each Reel

Dimension	Min	Max	Unit
A		178	mm
B	1.5		mm
C	12.80	13.50	mm
D	20.2		mm
N	50		mm
W ₁ (measured at hub)	8.4	9.9	mm
W ₂ (measured at hub)		14.4	mm
W ₃ (includes flange distortion at outer edge)	7.9	10.9	mm
Trailer	160		mm
Leader	390, of which minimum 160 mm of empty carrier tape sealed with cover tape		mm

PACKAGE OUTLINE (QFN-6)

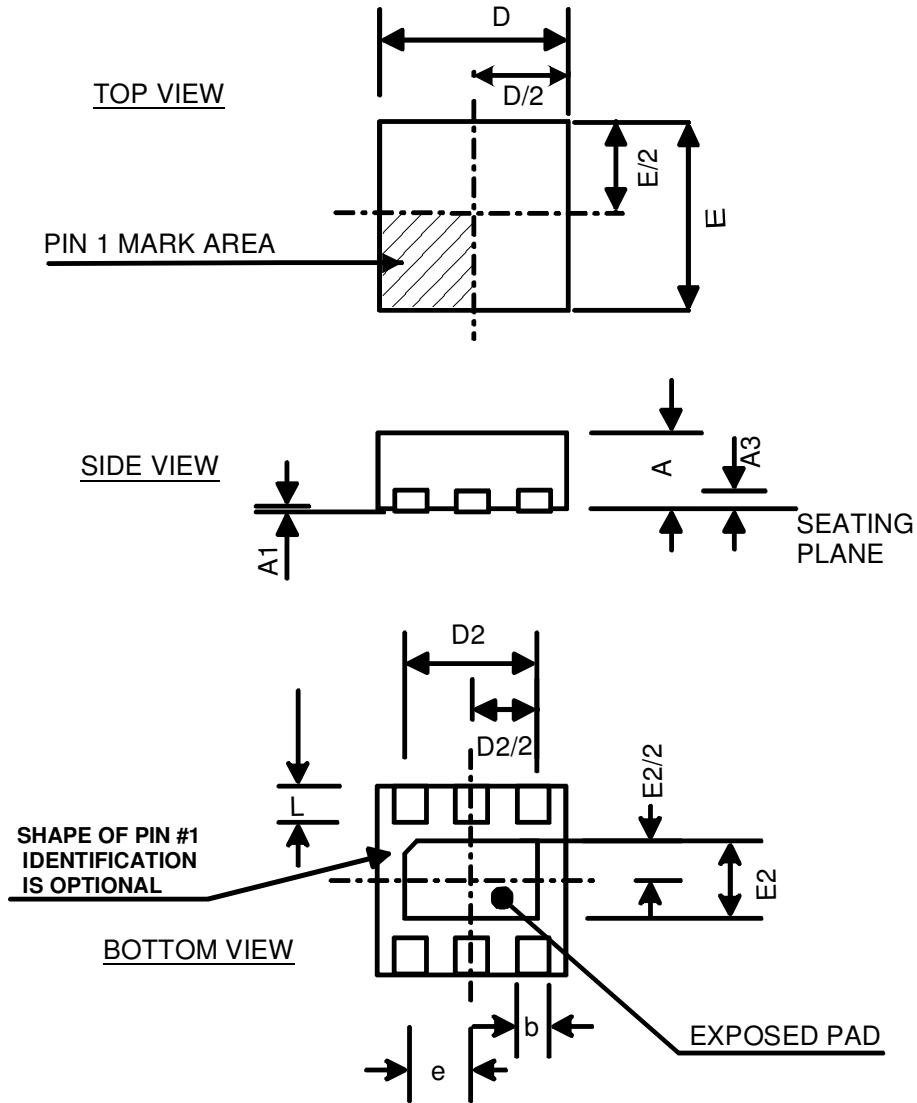

Symbol	Min	Nom	Max	Unit
PACKAGE DIMENSIONS				
A	0.700	0.750	0.800	mm
A1	0.000	0.020	0.050	mm
A3	0.178	0.203	0.228	mm
b	0.200	0.250	0.300	mm
D	2.000 BSC			mm
D2 (Exposed pad)	1.350	1.400	1.450	mm
E	2.000 BSC			mm
E2 (Exposed pad)	0.750	0.800	0.850	mm
e	0.650 BSC			mm
L	0.300	0.350	0.400	mm

Dimensions do not include mold or interlead flash, protrusions or gate burrs.

SOLDERING INFORMATION (QFN-6)
◆ For Lead-Free / RoHS Compliant Green QFN

Resistance to Soldering Heat	According to RSH test IEC 68-2-58/20
Maximum Temperature	260°C
Maximum Number of Reflow Cycles	3
Reflow profile	Thermal profile parameters stated in IPC/JEDEC J-STD-020 should not be exceeded. http://www.jedec.org
Lead Finish	7.62 - 25.4 µm, Matte Tin

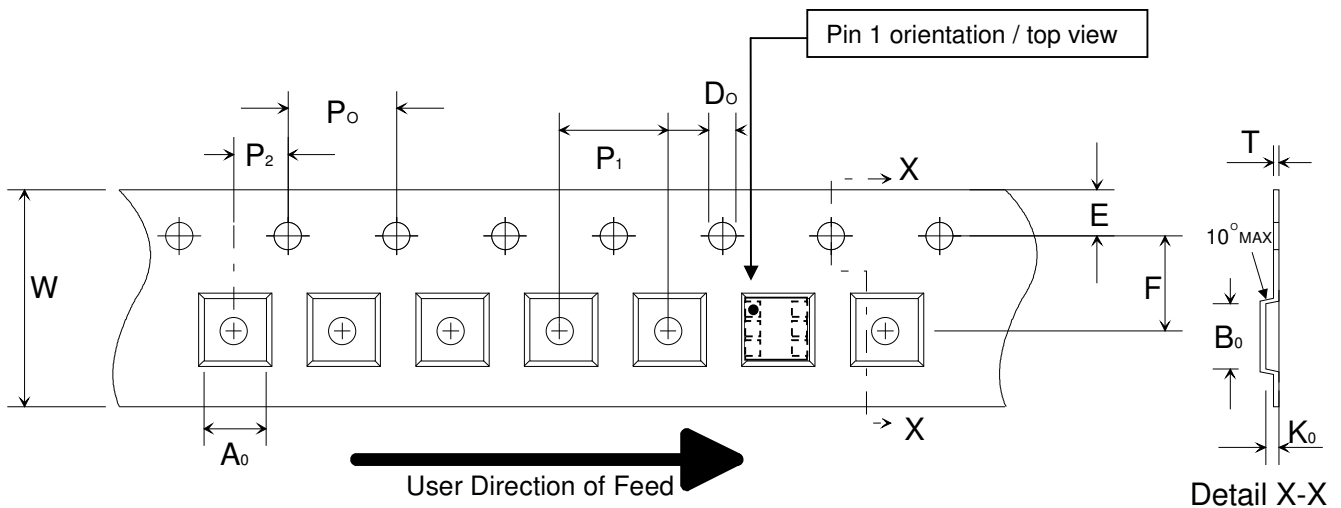
EMBOSED TAPE SPECIFICATIONS (QFN-6)

Dimension	Min/Max	Unit
A ₀	2.30 ±0.05	mm
B ₀	2.30 ±0.05	mm
D ₀	1.50 +0.1/-0.0	mm
E	1.75 ±0.10	mm
F	3.50 ±0.05	mm
K ₀	1.00 ±0.05	mm
P ₀	4.0	mm
P ₁	4.0 ±0.10	mm
P ₂	2.0 ±0.05	mm
T	0.254 ±0.02	mm
W	8.00 ±0.3/-0.1	mm

REEL SPECIFICATIONS (QFN-6)

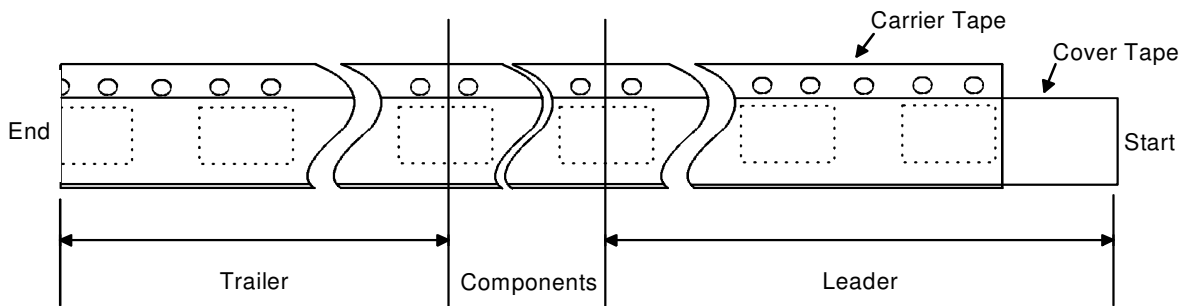
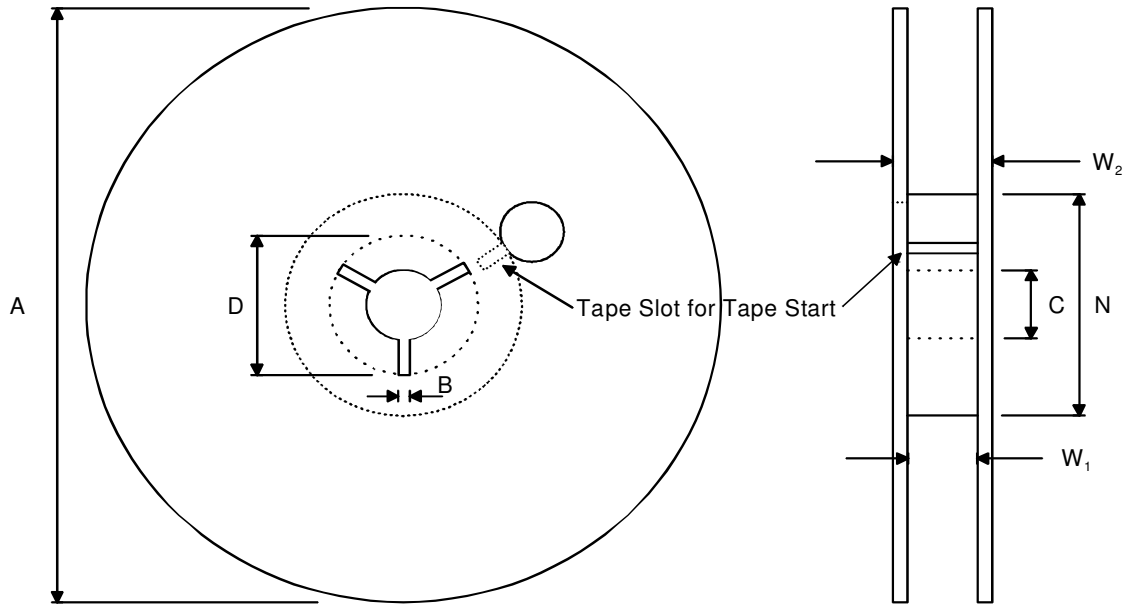

Dimension	Min	Max	Unit
A		178	mm
B	1.5		mm
C	12.80	13.50	mm
D	20.2		mm
N	50		mm
W ₁ (measured at hub)	8.4	9.90	mm
W ₂ (measured at hub)		14.4	mm
Trailer	160		mm
Leader	390, of which minimum 160 mm of empty carrier tape sealed with cover tape		mm

3000 Components on Each Reel

Reel Material: Conductive, Plastic Antistatic or Static Dissipative
Carrier Tape Material: Conductive

ORDERING INFORMATION

Product Code	Product	Package	Comments
MAS6285AA1WA900	IC FOR XO Trimming	Tested wafers 215 µm	
MAS6285AA1T0206	IC FOR XO Trimming	TSOT-6 Pb-free, RoHS compliant	T&R/3000 pcs/reel
MAS6285AA1Q1806	IC FOR XO Trimming	QFN-6 Pb-free, RoHS compliant	T&R/3000 pcs/reel

Please contact Micro Analog Systems Oy for other wafer thickness options.

◆ The formation of product code

Product name	Design version	Package type	Delivery format
MAS6285	AA1	WA9 = 215 µm thick EWS tested wafer	00 = bare wafer
		T02 = TSOT-6 RoHS Compliant	06 = tape & reel
		Q18 = QFN-6 RoHS Compliant	

LOCAL DISTRIBUTOR

MICRO ANALOG SYSTEMS OY CONTACTS

Micro Analog Systems Oy Kamreerintie 2, P.O. Box 51 FIN-02771 Espoo, FINLAND http://www.mas-oy.com	Tel. (09) 80 521 Tel. Int. +358 9 80 521 Telefax +358 9 805 3213 Email: info@mas-oy.com
---	---

NOTICE

Micro Analog Systems Oy reserves the right to make changes to the products contained in this data sheet in order to improve the design or performance and to supply the best possible products. Micro Analog Systems Oy assumes no responsibility for the use of any circuits shown in this data sheet, conveys no license under any patent or other rights unless otherwise specified in this data sheet, and makes no claim that the circuits are free from patent infringement. Applications for any devices shown in this data sheet are for illustration only and Micro Analog Systems Oy makes no claim or warranty that such applications will be suitable for the use specified without further testing or modification.