

MAS6179

This is preliminary information on a new product under development. Micro Analog Systems Oy reserves the right to make any changes without notice.

AM Receiver IC

Preliminary

- Tri Band Receiver IC
- High Sensitivity
- Very Low Power Consumption
- Wide Supply Voltage Range
- Power Down Control
- Control for AGC On
- High Selectivity by Crystal Filter
- Fast Startup Feature

DESCRIPTION

The MAS6179 AM-Receiver chip is a highly sensitive, simple to use AM receiver specially intended to receive time signals in the frequency range from 40 kHz to 100 kHz. Only a few external components are required for time signal receiving. The circuit has preamplifier, wide range automatic gain control, demodulator and output comparator built in. The output signal can be processed directly by an additional digital circuitry to extract the data from the received signal. The control for AGC (automatic gain

control) can be used to switch AGC on or off if necessary. MAS6179 supports up to three frequency band operation by switching between three crystal filters and two additional antenna tuning capacitors.

MAS6179 has differential input and two internal compensation capacitor options for compensating shunt capacitances of different crystals (See ordering information on page 14).

FEATURES

- Tri Band Receiver IC
- Highly Sensitive AM Receiver, 0.4 μV_{RMS} typ.
- Wide Supply Voltage Range from 1.1 V to 3.6 V
- Very Low Power Consumption
- Power Down Control
- Fast Startup
- Only a Few External Components Necessary
- Control for AGC On
- Wide Frequency Range from 40 kHz to 100 kHz
- High Selectivity by Quartz Crystal Filter
- Differential Input

APPLICATIONS

- Multi Band Time Signal Receiver WWVB (USA), JJY (Japan), DCF77 (Germany), MSF (UK), HBG (Switzerland) and BPC (China)

BLOCK DIAGRAM

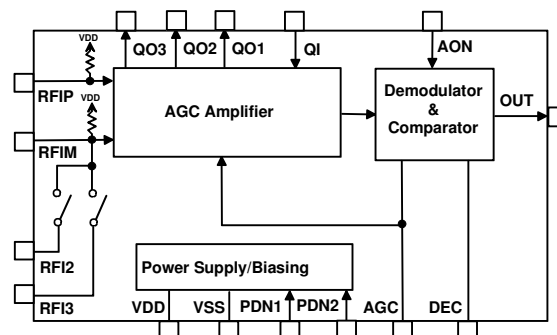

PAD LAYOUT

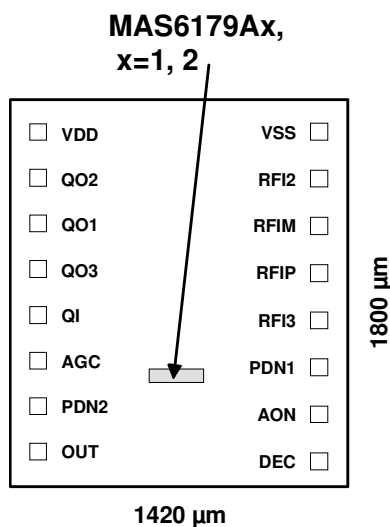

DIE size = 1.42 x 1.80 mm; rectangular PAD 80 μm x 80 μm

Note: Because the substrate of the die is internally connected to VSS, the die has to be connected to VSS or left floating. Please make sure that VSS is the first pad to be bonded. Pick-and-place and all component assembly are recommended to be performed in ESD protected area.

Note: Coordinates are pad center points where origin has been located in bottom-left corner of the silicon die.

Pad Identification	Name	X-coordinate	Y-coordinate	Note
Power Supply Voltage	VDD	154 μm	1580 μm	
Quartz Filter Output for Crystal 2	QO2	154 μm	1393 μm	
Quartz Filter Output for Crystal 1	QO1	154 μm	1207 μm	
Quartz Filter Output for Crystal 3	QO3	154 μm	1021 μm	
Quartz Filter Input for Crystals	QI	154 μm	835 μm	
AGC Capacitor	AGC	154 μm	648 μm	
Power Down/Frequency Selection Input 2	PDN2	154 μm	462 μm	1
Receiver Output	OUT	154 μm	276 μm	2
Demodulator Capacitor	DEC	1266 μm	276 μm	
AGC On Control	AON	1266 μm	462 μm	3
Power Down/Frequency Selection Input 1	PDN1	1266 μm	648 μm	1
Receiver Input 3 (for Antenna Capacitor 3)	RFI3	1266 μm	835 μm	
Positive Receiver Input	RFIP	1266 μm	1021 μm	4
Negative Receiver Input	RFIM	1266 μm	1207 μm	4
Receiver Input 2 (for Antenna Capacitor 2)	RFI2	1266 μm	1393 μm	
Power Supply Ground	VSS	1266 μm	1580 μm	

Notes:

- 1) PDN1 = PDN2 = VDD means receiver off
 - Fast start-up is triggered when the receiver is after power down controlled to power up
- 2) OUT = VSS when carrier amplitude at maximum; OUT = VDD when carrier amplitude is reduced (modulated)
 - the output is a current source/sink with $|I_{OUT}| > 5 \mu A$
 - at power down the output is pulled to VSS (pull down switch)
- 3) AON = VSS means AGC off (hold current gain level); AON = VDD means AGC on (working)
 - Internal pull-up with current $< 1 \mu A$ which is switched off at power down
- 4) Receiver inputs RFIP and RFIM have both 600 kΩ biasing resistors towards VDD

ABSOLUTE MAXIMUM RATINGS

Parameter	Symbol	Conditions	Min	Max	Unit
Supply Voltage	$V_{DD}-V_{SS}$		-0.3	5.5	V
Input Voltage	V_{IN}		$V_{SS}-0.3$	$V_{DD}+0.3$	V
Power Dissipation	P_{MAX}			100	mW
Operating Temperature	T_{OP}		-20	+70	°C
Storage Temperature	T_{ST}		-55	+150	°C

ELECTRICAL CHARACTERISTICS

Operating Conditions: VDD = 1.5V, Temperature = 25°C unless otherwise noted

Parameter	Symbol	Conditions	Min	Typ	Max	Unit
Operating Voltage	V_{DD}		1.10		3.6	V
Current Consumption	I_{DD}	VDD=1.5 V, Vin=0 μ Vrms VDD=1.5 V, Vin=20 mVrms VDD=3.6 V, Vin=0 μ Vrms VDD=3.6 V, Vin=20 mVrms	40 24	55 40 58 43	80 65	μ A
Stand-By Current	I_{DDoff}				0.1	μ A
Input Frequency Range	f_{IN}		40		100	kHz
Minimum Input Voltage	$V_{IN\ min}$			0.4	1	μ Vrms
Maximum Input Voltage	$V_{IN\ max}$		20			mVrms
Receiver Input Resistance Receiver Input Capacitance	R_{RF1} C_{RF1}	f=40kHz..77.5 kHz		600 0.5		k Ω pF
RFI2 Switch On Resistance RFI2 Switch Off Capacitance	R_{ON2} C_{OFF2}	VDD=1.4 V		5 TBD	15	Ω pF
RFI3 Switch On Resistance RFI3 Switch Off Capacitance	R_{ON3} C_{OFF3}	VDD=1.4 V		2.5 TBD	15	Ω pF
Input Levels $ I_{IN} < 0.5 \mu A$	V_{IL} V_{IH}		$V_{DD}-0.35$		0.35	V
Output Current $V_{OL} < 0.2 V_{DD}; V_{OH} > 0.8 V_{DD}$	$ I_{OUT} $		5			μ A
Output Pulse	T_{100ms}	$1 \mu Vrms \leq V_{IN} \leq 20 mVrms$	50		140	ms
	T_{200ms}	$1 \mu Vrms \leq V_{IN} \leq 20 mVrms$	150		230	ms
	T_{500ms}	$1 \mu Vrms \leq V_{IN} \leq 20 mVrms$	400	500	600	ms
	T_{800ms}	$1 \mu Vrms \leq V_{IN} \leq 20 mVrms$	700	800	900	ms
Startup Time	T_{Start}	Fast Start-up, Vin=0.4 μ Vrms Fast Start-up, Vin=20 mVrms		1.3 3.5		s
Output Delay Time	T_{Delay}			50	100	ms

Note: Stand-by current consumption may increase if V_{IH} and V_{IL} differ from VDD and GND respectively.
TBD = To Be Defined

FREQUENCY SELECTION

The frequency selection and power down control is accomplished via two digital control pins PDN1 and PDN2. The control logic is presented in table 1.

Table 1. Frequency selection and power down control

PDN1	PDN2	RFI2 Switch	RFI3 Switch	Selected Crystal Output	Description
High	High	Open	Open	-	Power down
High	Low	Open	Open	QO1	Frequency 1
Low	High	Closed	Open	QO2	Frequency 2, RFI2 capacitor connected in parallel with antenna
Low	Low	Closed	Closed	QO3	Frequency 3, RFI2 and RFI3 capacitors connected in parallel with antenna

The internal antenna tuning capacitor switches (RFI2, RFI3) and crystal filter output switches (QO1, QO2, QO3) are controlled according table 1.

If frequency 1 is selected the RFI2 and RFI3 switches are open and only crystal output QO1 is active. Antenna frequency is determined by antenna inductor L_{ANT} (see Typical Application on page 6), antenna capacitor C_{ANT1} and parasitic capacitances related to antenna inputs RFIP, RFIM, RFI2 and RFI3 (see Antenna Tuning Considerations below). Frequency 1 is the highest frequency of the three selected frequencies.

If frequency 2 is selected then RFI2 switch is closed to connect C_{ANT2} to pin RFIM in parallel with ferrite antenna and tune it to frequency 2. Then only crystal output QO2 is active. Frequency 2 is the medium frequency of the three selected frequencies.

If frequency 3 is selected both RFI2 and RFI3 switches are closed to connect both C_{ANT2} and C_{ANT3} capacitors to RFIM pin in parallel with ferrite antenna and tune it to frequency 3. Then only crystal output QO3 is active. Frequency 3 is the lowest frequency of the three selected frequencies.

It is recommended to switch the device to power down for at least 50ms before switching to another frequency. This guarantees fast startup in switching to another frequency. During minimum 50ms power down time the AGC capacitor voltage is completely pulled to VDD and the proper fast startup conditions are met. Without proper fast startup control the startup time can be several minutes. With fast startup it is shortened typically to few seconds.

ANTENNA TUNING CONSIDERATIONS

The ferrite bar antenna having inductance L_{ANT} and parasitic coil capacitance C_{COIL} is tuned to three reception frequencies f_1 , f_2 and f_3 by parallel capacitors C_{ANT1} , C_{ANT2} and C_{ANT3} . The receiver input stage and internal antenna capacitor switches have capacitances C_{RFI} , C_{OFF2} , C_{OFF3} which affect

the resonance frequencies. C_{OFF2} and C_{OFF3} are switch capacitances when switches are open. When switches are closed these capacitances are shorted by on resistance of the switches and they are effectively eliminated. Following relationships can be written for the three tuning frequencies.

Frequency f_1 (highest frequency):

$$C_{TOT1} = C_{COIL} + C_{ANT1} + C_{RFI} + C_{OFF2} + C_{OFF3}$$

$$f_1 = \frac{1}{2\pi\sqrt{L_{ANT} \cdot C_{TOT1}}}$$

Frequency f_2 (middle frequency):

$$C_{TOT2} = C_{COIL} + C_{ANT1} + C_{ANT2} + C_{RFI} + C_{OFF3}$$

$$f_2 = \frac{1}{2\pi\sqrt{L_{ANT} \cdot C_{TOT2}}}$$

Frequency f_3 (lowest frequency):

$$C_{TOT3} = C_{COIL} + C_{ANT1} + C_{ANT2} + C_{ANT3} + C_{RFI}$$

$$f_3 = \frac{1}{2\pi\sqrt{L_{ANT} \cdot C_{TOT3}}}$$

TYPICAL APPLICATION

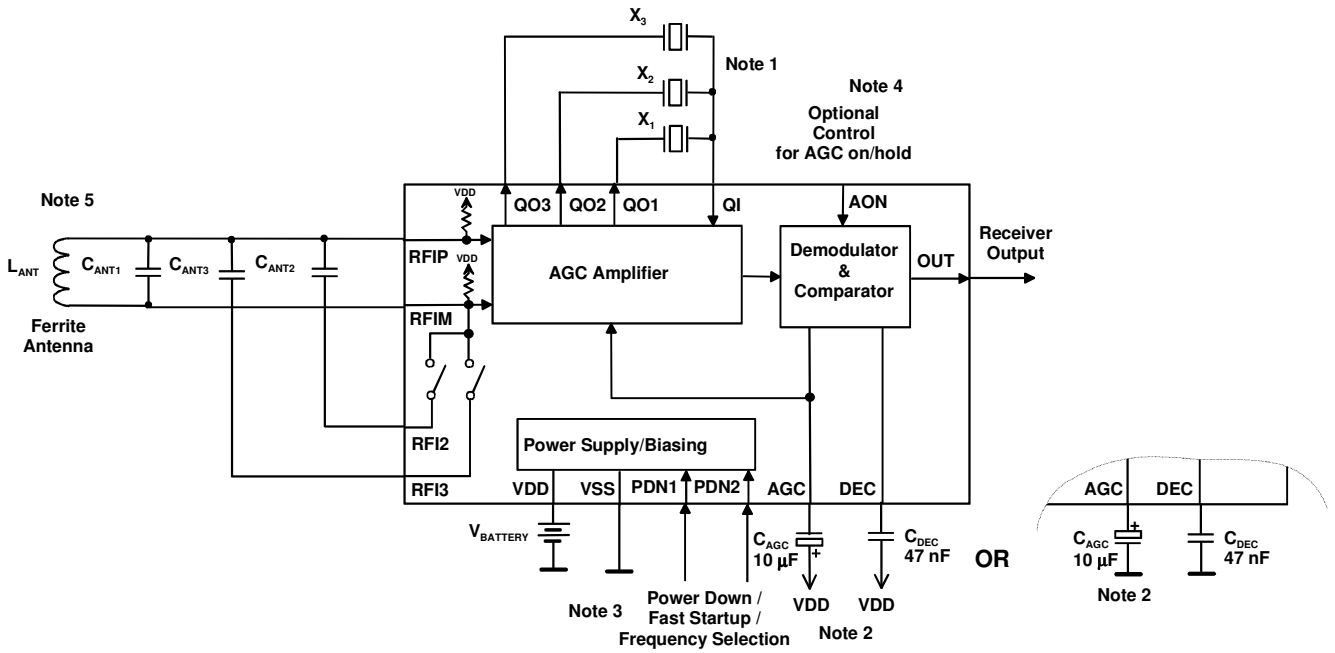

Figure 1. Application circuit of tri band receiver MAS6179.

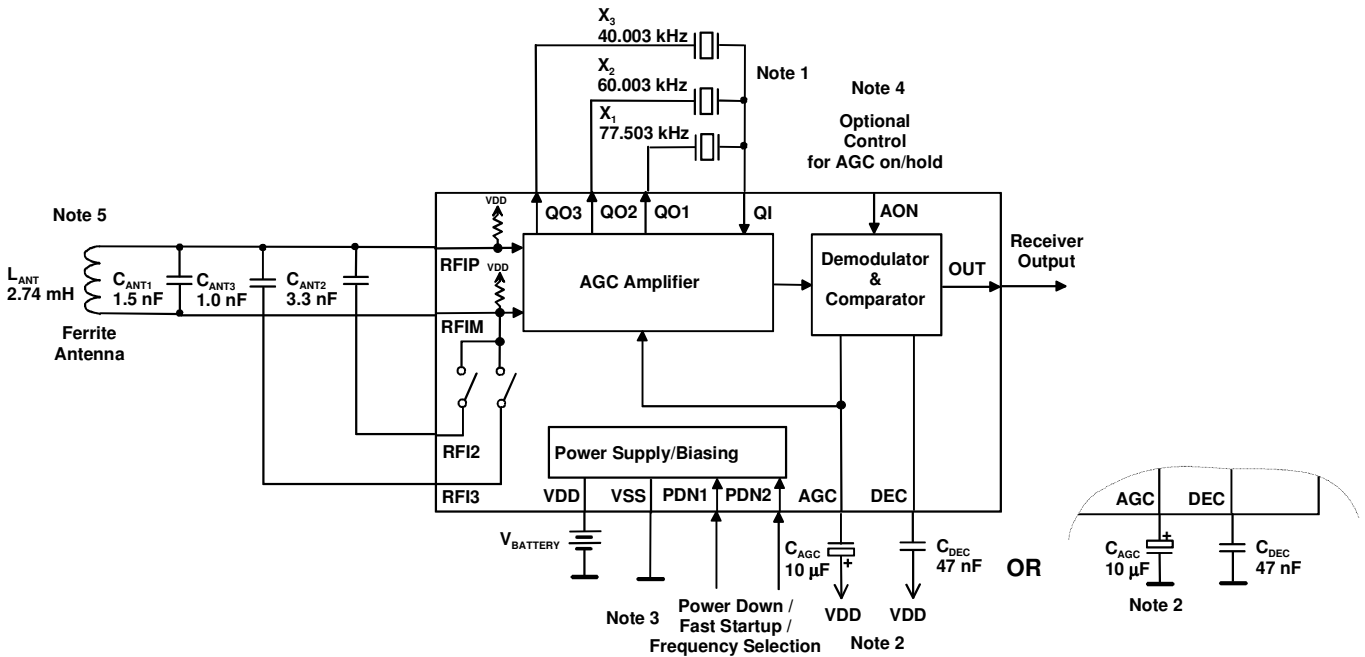

Figure 2. Example circuit of tri band receiver MAS6179 for DCF77/MSF/WWVB/JJY frequencies.

TYPICAL APPLICATION (Continued)

Note 1: Crystals

The crystals as well as ferrite antenna frequencies are chosen according to the time signal system (Table 2). The reason why the crystal frequency is about 3 Hz higher than the signal frequency is that the crystal is operated without the loading capacitor. Without loading capacitor the actual resonance frequency is about 3 Hz lower thus 77.503 kHz crystal resonates at 77.500 kHz when no loading capacitor is used.

Table 2. Time Signal System Frequencies

Time Signal System	Location	Antenna Frequency	Recommended Crystal Frequency
DCF77	Germany	77.5 kHz	77.503 kHz
HBG	Switzerland	75 kHz	75.003 kHz
MSF	United Kingdom	60 kHz	60.003 kHz
WWVB	USA	60 kHz	60.003 kHz
JJY	Japan	40 kHz and 60 kHz	40.003 kHz and 60.003 kHz
BPC	China	68.5 kHz	68.505 kHz

The crystal shunt capacitance C_0 should be matched as well as possible with the internal shunt capacitance compensation capacitor C_c of MAS6179. See Compensation Capacitance Options in table 3.

Table 3. Compensation Capacitance Options

Device	C_c	Crystal Description
MAS6179A1	0.75 pF	For low C_0 crystal
MAS6179A2	1.3 pF	For high C_0 crystal

It should be noted that grounded crystal package has reduced shunt capacitance. This value is about 85% of floating crystal shunt capacitance. For example crystal with 1pF floating package shunt capacitance can have 0.85pF grounded package shunt capacitance. PCB traces of crystal and external compensation capacitance should be kept at minimum to minimize additional parasitic capacitance which can cause capacitance mismatching.

Highest frequency crystal is connected to crystal output pin 1 (QO1). Medium frequency crystal is connected to crystal output pin 2 (QO2). Lowest frequency crystal is connected to crystal output pin 3 (QO3). The other pin of each crystal is connected to common crystal input pin QI.

Table 4 below presents some crystal manufacturers having suitable crystals for time signal receiver application.

Table 4. Crystal Manufacturers and Crystal Types in Alphabetical Order for Time Signal Receiver Application

Manufacturer	Crystal Type	Dimensions	Web Link
Citizen	CFV-206	ø 2.0 x 6.0	http://www.citizen.co.jp/tokuhan/quartz/
Epson	C-2-Type	ø 1.5 x 5.0	http://www.epsontoyocom.co.jp/english/
	C-4-Type	ø 2.0 x 6.0	
KDS Daishinku	DT-261	ø 2.0 x 6.0	http://www.kds.info/index_en.htm
Microcrystal	MX1V-L2N	ø 2.0 x 6.0	http://www.microcrystal.com/
	MX1V-T1K	ø 2.0 x 8.1	
Seiko Instruments	VTC-120	ø 1.2 x 4.7	http://www.sii-crystal.com

Note 2: AGC Capacitor

The AGC and DEC capacitors must have low leakage currents due to very small signal currents through the capacitors. The insulation resistance of these capacitors should be at minimum 100 MΩ. Also probes with at least 100 MΩ impedance should be used for voltage probing of AGC and DEC pins. Electrolytic AGC capacitor should have voltage rating at least 25 V for low enough leakage. DEC capacitor can be low leakage chip capacitor.

TYPICAL APPLICATION (Continued)

Both the AGC and DEC capacitors can be connected either to VDD or to VSS. To minimize leakage currents during power down the AGC and DEC capacitors are best to be connected to VDD since in power down the AGC and DEC pins go to VDD voltage potential. In this case the positive polarity pin of electrolyte capacitor should be connected to VDD. If the capacitors are connected to VSS then the negative polarity pin of electrolyte capacitor should be connected to VSS.

Note 3: Power Down / Fast Startup Control

Both power down and fast startup are controlled using the PDN pin. The device is in power down (turned off) if PDN1 = PDN2 = VDD and in power up with other three PDN1 and PDN2 control bit combinations (see table 1 on page 4). Fast startup is triggered automatically when moving from power down to power up. The VDD must have been high before moving from power down to power up to guarantee proper operation of fast startup circuitry. Additionally the device should have been kept in power down state at least 50ms before power up. This guarantees that the AGC capacitor voltage has been completely pulled to VDD during power down. The startup time without proper fast startup control can be several minutes. With fast startup it is shortened typically to few seconds.

Note 4: Optional Control for AGC On/Hold

AON control pin has internal pull up which turns AGC circuit on all the time if AON pin is left unconnected. Optionally AON control can be used to hold and release AGC circuit. Stepper motor drive of analog clock or watch can produce disturbing amount of noise which can shift the input amplifier gain to unoptimal level. This can be avoided by controlling AGC hold (AON=VSS) during stepper motor drive periods and releasing AGC (AON=VDD) when motors are not driven. The AGC should be in hold only during disturbances and kept on other time released since due to leakage the AGC can change slowly when in hold.

Note 5: Ferrite Antenna

The ferrite antenna converts the transmitted radio wave into a voltage signal. It has an important role in determining receiver performance. Recommended antenna impedance at resonance is around 150 kΩ.

Low antenna impedance corresponds to low noise but often also to small signal amplitude. On the other hand high antenna impedance corresponds to high noise but also large signal. The optimum performance where signal-to-noise ratio is at maximum is achieved in between.

The antenna should have also some selectivity for rejecting near signal band disturbances. This is determined by the antenna quality factor which should be approximately 100. Much higher quality factor antennas suffer from extensive tuning accuracy requirements and possible tuning drifts by the temperature.

Antenna impedance can be calculated using equation 1 where f_0 , L , Q_{ant} and C are resonance frequency, coil inductance, antenna quality factor and antenna tuning capacitor respectively. Antenna quality factor Q_{ant} is defined by ratio of resonance frequency f_0 and antenna bandwidth B (equation 2).

$$R_{antenna} = 2\pi \cdot f_0 \cdot L \cdot Q_{antenna} = \frac{Q_{antenna}}{2\pi \cdot f_0 \cdot C} = \frac{1}{2\pi \cdot B \cdot C} \quad \text{Equation 1.}$$

$$Q_{antenna} = \frac{f_0}{B} \quad \text{Equation 2.}$$

Table 5 below presents some antenna manufacturers for time signal application.

Table 5. Antenna Manufacturers and Antenna Types in Alphabetical Order for Time Signal Application

Manufacturer	Antenna Type	Dimensions	Web Link
HR Electronic GmbH	60716 (60kHz) 60708 (77.5kHz)	ø 10 x 60 mm	http://www.hrelectronic.com/
Sumida	ACL80A (40kHz)	ø 10 x 80 mm	www.sumida.co.jp/jeita/XJA021.pdf

MAS6179 SAMPLES IN SBDIL 20 PACKAGE

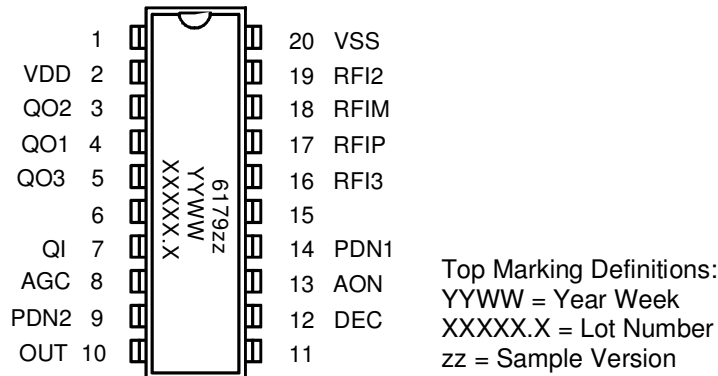

PIN DESCRIPTION

Pin Name	Pin	Type	Function	Note
	1	NC		
VDD	2	P	Positive Power Supply	
QO2	3	AO	Quartz Filter Output for Crystal 2	
QO1	4	AO	Quartz Filter Output for Crystal 1	
QO3	5	AO	Quartz Filter Output for Crystal 3	
	6	NC		1
QI	7	AI	Quartz Filter Input for Crystal	
AGC	8	AO	AGC Capacitor	
PDN2	9	DI	Power Down/Frequency Selection Input 2	2
OUT	10	DO	Receiver Output	3
	11	NC		
DEC	12	AO	Demodulator Capacitor	
AON	13	DI	AGC On Control	4
PDN1	14	DI	Power Down/Frequency Selection Input 1	2
	15	NC		
RFI3	16	AI	Receiver Input 3 (for Antenna Capacitor 3)	
RFIP	17	AI	Positive Receiver Input	5
RFIM	18	AI	Negative Receiver Input	5
RFI2	19	AI	Receiver Input 2 (for Antenna Capacitor 2)	
VSS	20	G	Power Supply Ground	

A = Analog, D = Digital, P = Power, G = Ground, I = Input, O = Output, NC = Not Connected

Notes:

- 1) Pin 6 between QO3 and QI must be connected to VSS to eliminate DIL package lead frame parasitic capacitances disturbing the crystal filter performance. All other NC (Not Connected) pins are also recommended to be connected to VSS to minimize noise coupling.
- 2) PDN1 = PDN2 = VDD means receiver off
 - Fast start-up is triggered when the receiver is after power down controlled to power up
- 3) OUT = VSS when carrier amplitude at maximum; OUT = VDD when carrier amplitude is reduced (modulated)
 - the output is a current source/sink with $|I_{OUT}| > 5 \mu A$
 - at power down the output is pulled to VSS (pull down switch)
- 4) AON = VSS means AGC off (hold current gain level); AON = VDD means AGC on (working)
 - Internal pull-up with current $< 1 \mu A$ which is switched off at power down
- 5) Receiver inputs RFIP and RFIM have both 600 k Ω biasing resistors towards VDD

PIN CONFIGURATION & TOP MARKING FOR PLASTIC TSSOP-16 PACKAGE

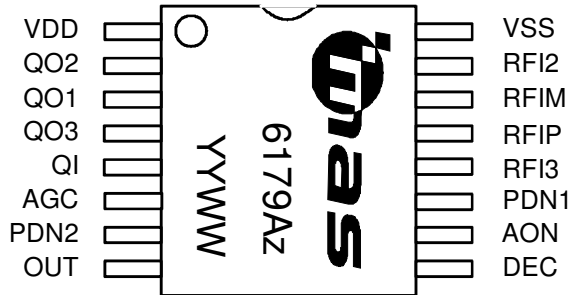

Top Marking Definitions:
 z = Version Number
 YYWW = Year Week

PIN DESCRIPTION

Pin Name	Pin	Type	Function	Note
VDD	1	P	Positive Power Supply	
QO2	2	AO	Quartz Filter Output for Crystal 2	
QO1	3	AO	Quartz Filter Output for Crystal 1	
QO3	4	AO	Quartz Filter Output for Crystal 3	
QI	5	AI	Quartz Filter Input for Crystal and External Compensation Capacitor	
AGC	6	AO	AGC Capacitor	
PDN2	7	DI	Power Down/Frequency Selection Input 2	1
OUT	8	DO	Receiver Output	2
DEC	9	AO	Demodulator Capacitor	
AON	10	DI	AGC On Control	3
PDN1	11	DI	Power Down/Frequency Selection Input 1	1
RF13	12	AI	Receiver Input 3 (for Antenna Capacitor 3)	
RFIP	13	AI	Positive Receiver Input	4
RFIM	14	AI	Negative Receiver Input	4
RFI2	15	AI	Receiver Input 2 (for Antenna Capacitor 2)	
VSS	16	G	Power Supply Ground	

A = Analog, D = Digital, P = Power, G = Ground, I = Input, O = Output, NC = Not Connected

Notes:

- 1) PDN1 = PDN2 = VDD means receiver off
 - Fast start-up is triggered when the receiver is after power down controlled to power up
- 2) OUT = VSS when carrier amplitude at maximum; OUT = VDD when carrier amplitude is reduced (modulated)
 - the output is a current source/sink with $|I_{OUT}| > 5 \mu A$
 - at power down the output is pulled to VSS (pull down switch)
- 3) AON = VSS means AGC off (hold current gain level); AON = VDD means AGC on (working)
 - Internal pull-up with current $< 1 \mu A$ which is switched off at power down
- 4) Receiver inputs RFIP and RFIM have both 600 k Ω biasing resistors towards VDD.

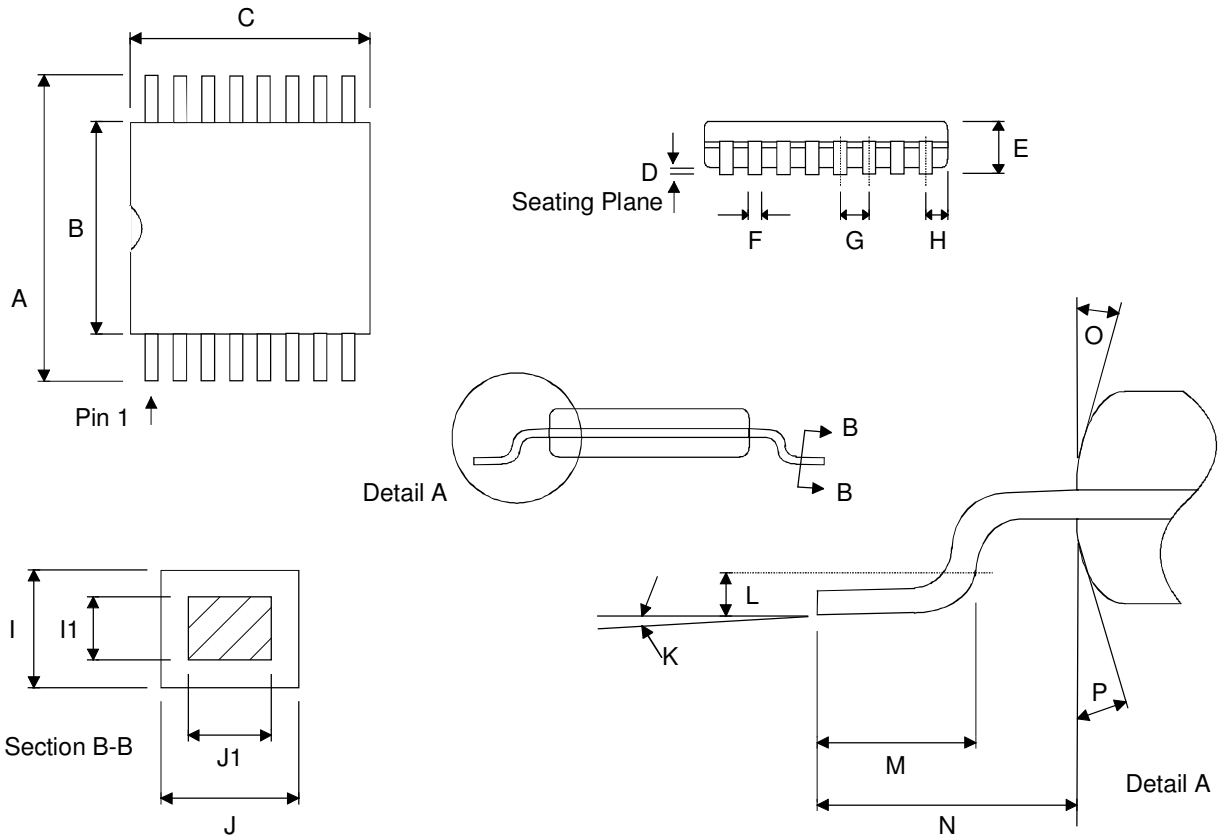
PACKAGE (TSSOP-16) OUTLINES

Dimension	Min	Max	Unit
A	6.40 BSC		mm
B	4.30	4.50	mm
C	5.00 BSC		mm
D	0.05	0.15	mm
E		1.10	mm
F	0.19	0.30	mm
G	0.65 BSC		mm
H	0.18	0.28	mm
I	0.09	0.20	mm
I1	0.09	0.16	mm
J	0.19	0.30	mm
J1	0.19	0.25	mm
K	0°	8°	
L	0.24	0.26	mm
M	0.50	0.75	mm
(The length of a terminal for soldering to a substrate)			
N	1.00 REF		mm
O	12°		
P	12°		

Dimensions do not include mold flash, protrusions, or gate burrs.
 All dimensions are in accordance with JEDEC standard MO-153.

SOLDERING INFORMATION

◆ For Pb-Free, RoHS Compliant TSSOP-16

Resistance to Soldering Heat	According to RSH test IEC 68-2-58/20
Maximum Temperature	260°C
Maximum Number of Reflow Cycles	3
Reflow profile	Thermal profile parameters stated in IPC/JEDEC J-STD-020 should not be exceeded. http://www.jedec.org
Seating Plane Co-planarity	max 0.08 mm
Lead Finish	Solder plate 7.62 - 25.4 μm, material Matte Tin

EMBOSED TAPE SPECIFICATIONS

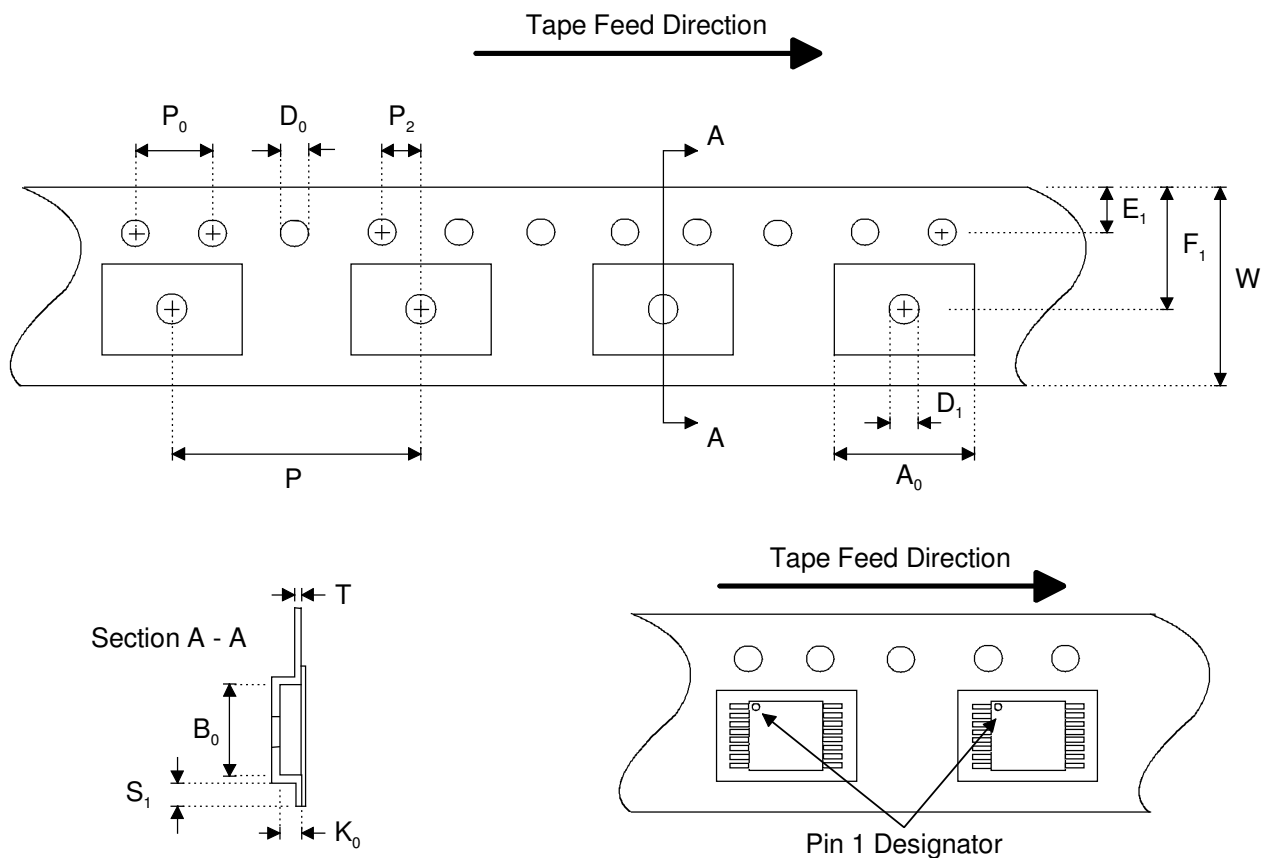

Dimension	Min	Max	Unit
A ₀	6.50	6.70	mm
B ₀	5.20	5.40	mm
D ₀	1.50 +0.10 / -0.00		mm
D ₁	1.50		mm
E ₁	1.65	1.85	mm
F ₁	7.20	7.30	mm
K ₀	1.20	1.40	mm
P	11.90	12.10	mm
P ₀	4.0		mm
P ₂	1.95	2.05	mm
S ₁	0.6		mm
T	0.25	0.35	mm
W	11.70	12.30	mm

REEL SPECIFICATIONS

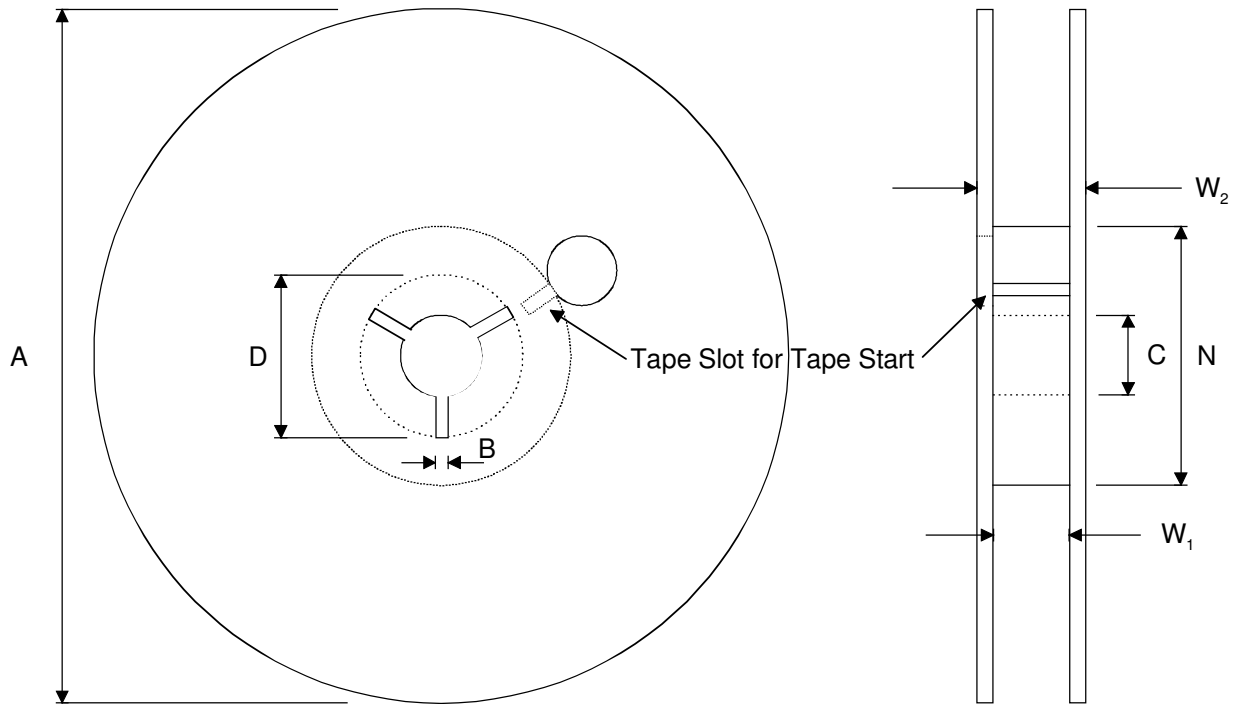

2000 Components on Each Reel

Reel Material: Conductive, Plastic Antistatic or Static Dissipative

Carrier Tape Material: Conductive

Cover Tape Material: Static Dissipative

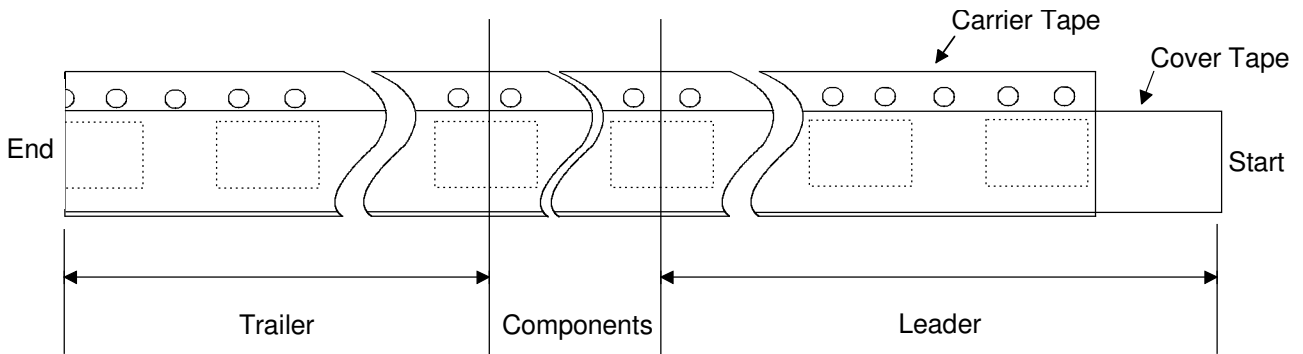

Dimension	Min	Max	Unit
A		330	mm
B	1.5		mm
C	12.80	13.50	mm
D	20.2		mm
N	50		mm
W ₁ (measured at hub)	12.4	14.4	mm
W ₂ (measured at hub)		18.4	mm
Trailer	160		mm
Leader	390, of which minimum 160 mm of empty carrier tape sealed with cover tape		mm
Weight		1500	g

ORDERING INFORMATION

Product Code	Product	Description	Capacitance Option
MAS6179A1TC00	Tri Band AM-Receiver IC with Differential Input	EWS-tested wafer, Thickness 400 μm .	$C_C = 0.75 \text{ pF}$
MAS6179A2TC00	Tri Band AM-Receiver IC with Differential Input	EWS-tested wafer, Thickness 400 μm .	$C_C = 1.3 \text{ pF}$
MAS6179A1UC06	Dual Band AM-Receiver IC with Differential Input	TSSOP-16, Pb-free, RoHS compliant, Tape & Reel	$C_C = 0.75 \text{ pF}$

Contact Micro Analog Systems Oy for other wafer thickness options.

◆ The formation of product code

An example for MAS6179A1TC00:

MAS6179	A	1	TC	00
Product name	Design version	Capacitance option: $C_C = 0.75 \text{ pF}$	Package type: TC = 400 μm thick EWS tested wafer	Delivery format: 00 = bare wafer 05 = dies on tray 06 = tape & reel 08 = in tube

LOCAL DISTRIBUTOR

MICRO ANALOG SYSTEMS OY CONTACTS

Micro Analog Systems Oy Kamreerintie 2, P.O. Box 51 FIN-02771 Espoo, FINLAND	Tel. +358 9 80 521 Fax +358 9 805 3213 http://www.mas-oy.com
--	--

NOTICE

Micro Analog Systems Oy reserves the right to make changes to the products contained in this data sheet in order to improve the design or performance and to supply the best possible products. Micro Analog Systems Oy assumes no responsibility for the use of any circuits shown in this data sheet, conveys no license under any patent or other rights unless otherwise specified in this data sheet, and makes no claim that the circuits are free from patent infringement. Applications for any devices shown in this data sheet are for illustration only and Micro Analog Systems Oy makes no claim or warranty that such applications will be suitable for the use specified without further testing or modification.