

# MAS1634

## Quad LED Driver IC

- **Quad Current Sink Output**
- **Wide Supply Voltage Range**
- **Low Power Consumption**
- **Power Down Control**

---

### DESCRIPTION

MAS1634 is a quad LED driver IC. It has four constant current sink type outputs for driving up to four LEDs. It has wide supply voltage range and low power consumption ideally suitable for low power applications. MAS1634 can be set into power down mode by a power down control pin. The LED driver

control inputs have pull down resistors and which are disabled in the power down mode.

---

### FEATURES

- Quad Current Sink Output, 2.1 mA typ
- Wide Supply Voltage Range from 1.0 V to 3.1 V
- Low Power Consumption
- Power Down Control

---

### APPLICATIONS

- LED Driver for Portable Low Power Application
- IR LED Driver for Optical Hand Position Detection of Radio Controlled Watch

## BLOCK DIAGRAM

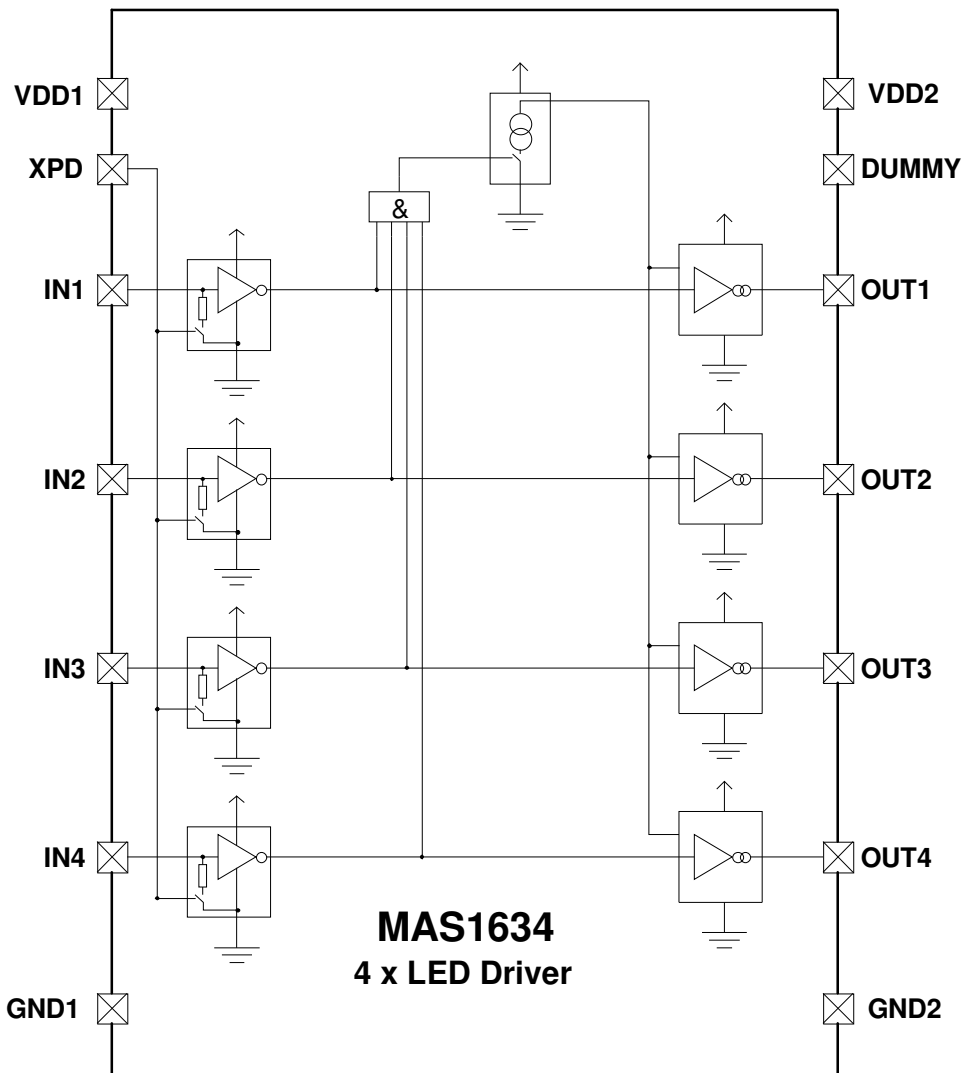

**Figure 1.** MAS1634 Block Diagram

Figure 1 presents MAS1634 block diagram. MAS1634 consists of four fixed current sink outputs for driving VDD connected LEDs. Each LED driver can be turned on or off independently. There is also common power-down control pin XPD which is active when low.

The dummy pad is electrically unconnected and its only purpose is to make the pad layout symmetrical

which helps in making the flip-chip connection even more reliable.

VDD1 and VDD2 power supply pins are internally connected making only one supply voltage connection necessary. Also GND1 and GND2 pins are internally connected so that it is necessary to connect only one of the two ground pins to supply ground.

## ABSOLUTE MAXIMUM RATINGS

Parameter	Symbol	Conditions	Min	Max	Unit
Supply Voltage	$V_{DD}$		-0.3	6.0	V
Storage Temperature	$T_{ST}$		-55	+125	°C
Input Voltage	$V_{IN}$		-0.3	VDD+0.3	V
Latch-up Current Limit	$I_{LUT}$	For all pins (see note 1)	-100	100	mA

Stresses beyond those listed may cause permanent damage to the device. The device may not operate under these conditions, but it will not be destroyed.

This is a CMOS device and therefore it should be handled carefully to avoid any damage by static voltages (ESD).

**Note 1.** In latch-up testing the supply voltages are connected normally to the tested device. Then pulsed test current is fed to each input separately and device current consumption is observed. If the device current consumption increases suddenly due to test current pulses and the abnormally high current consumption continues after test current pulses are cut off then the device has gone to latch up. Current pulse is turned on for 10 ms and off for 20 ms. Testing is done up to  $\pm 300$  mA.

## ELECTRICAL CHARACTERISTICS

(Operating Conditions: VDD = 2.0V, Temperature = 25°C unless otherwise mentioned)

Parameter	Symbol	Conditions	Min	Typ	Max	Unit
Supply Voltage	VDD		1.0	2.0	3.1	V
Operating Temperature	$T_A$		-20	+25	+60	°C
Standby Current	$I_{SS}$	XPD = "0"			0.5	μA
Quiescent Current	$I_{SC}$	XPD = "1", OUTPUTS OFF (INx="0") XPD = "1", 1 OUTPUT ON XPD = "1", 2 OUTPUTS ON XPD = "1", 3 OUTPUTS ON XPD = "1", 4 OUTPUTS ON		140 270 390 500	0.5 300 500 700 900	μA
Current driver	$I_{CD}$	XPD = "1" VDD = 0.95V, OUT1-4 = 0.075V VDD = 1.15V, OUT1-4 = 0.025V VDD = 1.15V, OUT1-4 = 0.075V VDD = 1.25V, OUT1-4 = 0.175V VDD = 1.70V, OUT1-4 = 0.625V	1.4 1 1.4 1.4 1.4	2.1 1.8 2.1 2.1 2.1	4.5 4.0 3.45 3 3	mA
Leakage current of an output	$I_{leak}$	VDD = 1.70 V, VOUT1-4 = VDD VIN1-4 = GND			100	nA
Input high voltage	$V_{IH}$		0.8*VDD		VDD	V
Input low voltage	$V_{IL}$		GND		0.2*VDD	V
Start up time	$t_{st}$	VDD = 1.15 V		15	50	μs

---

## FUNCTIONAL DESCRIPTION

---

### ◆ Main Functions

MAS1634 has two functional blocks. First is the *LED driver* to drive LEDs in a wrist watch applications. Second is *Bias voltage* generator for generating bias current for the drivers

### ◆ Operating Modes

MAS1634 has two operating modes. These modes are simply ON and OFF modes.

ON mode is selected when XPD is high. In ON mode each of the four output drivers can be switched on separately by setting each of the INx control inputs high. If control input is low the corresponding current output driver is off. If all control inputs are low the bias generator is turned off.

OFF mode is selected when XPD is low. In OFF mode the bias generator and the current drivers are in power down.

The device has two supply voltage pins VDD1 and VDD2 and which are internally connected. It is sufficient to connect only one of the two supply pins but if both supplies are connected then they should be connected to same voltage potential.

The device has also two supply ground pins GND1 and GND2 and which are internally connected. It is sufficient to connect only one of the two ground pins but if both grounds are connected then they should be connected to same ground potential.

### ◆ Inverting input buffer

The inverting buffers buffer the input signals. These blocks also contain pull-down resistors and they are switched in an inactive high impedance state if the XPD input is low.

If the XPD pin is high then the INx inputs have pull down by the pull down resistors. Nominally the values of the pull down resistors are 1.7 M $\Omega$  but they can vary  $\pm 15\%$ .

The XPD input doesn't have pull down resistor so this input must be driven by the controller or be connected to VDD (always ON mode) in order to achieve properly controlled operation.

### ◆ Output Driver

Four switchable low-voltage 2.1 mA constant current sinks with very low drop-out voltage are implemented to drive external VDD connected LEDs.

### ◆ Bias Generator

Bias voltage generator supplies bias current for the output drivers. It is turned on if XPD is high and if any of the four control inputs is high.

## MAS1634 PAD LAYOUT

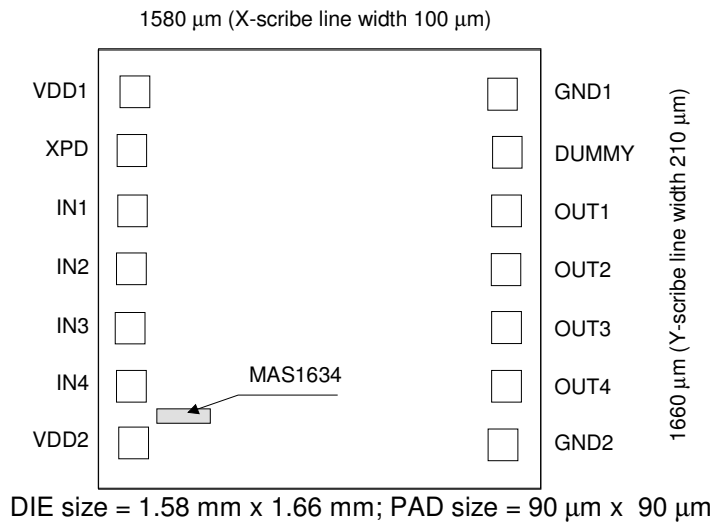

**Note:** Because the substrate of the die is internally connected to VSS, the die has to be connected to VSS or left floating. Please make sure that GND1 and GND2 are the first pads to be bonded. Pick-and-place and all component assembly are recommended to be performed in ESD protected area.

## MAS1634 PAD COORDINATES

**Note:** Coordinates are pad center points where origin has been located in bottom-left corner of the silicon die.

Pad Identification	Name	X-coordinate	Y-coordinate	Note
Positive Power Supply	VDD1	158 $\mu\text{m}$	1435 $\mu\text{m}$	1
Power Down Input	XPD	158 $\mu\text{m}$	1225 $\mu\text{m}$	3
LED Current Driver Input 1	IN1	158 $\mu\text{m}$	1014 $\mu\text{m}$	4
LED Current Driver Input 2	IN2	158 $\mu\text{m}$	814 $\mu\text{m}$	4
LED Current Driver Input 3	IN3	158 $\mu\text{m}$	603 $\mu\text{m}$	4
LED Current Driver Input 4	IN4	158 $\mu\text{m}$	392 $\mu\text{m}$	4
Positive Power Supply	VDD2	158 $\mu\text{m}$	182 $\mu\text{m}$	1
Power Supply Ground	GND1	1422 $\mu\text{m}$	1435 $\mu\text{m}$	2
Unused Dummy Pad	DUMMY	1422 $\mu\text{m}$	1225 $\mu\text{m}$	5
LED Current Driver Output 1	OUT1	1422 $\mu\text{m}$	1014 $\mu\text{m}$	
LED Current Driver Output 2	OUT2	1422 $\mu\text{m}$	814 $\mu\text{m}$	
LED Current Driver Output 3	OUT3	1422 $\mu\text{m}$	603 $\mu\text{m}$	
LED Current Driver Output 4	OUT4	1422 $\mu\text{m}$	392 $\mu\text{m}$	
Power Supply Ground	GND2	1422 $\mu\text{m}$	182 $\mu\text{m}$	2

**Notes:**

- 1) Keep VDD1 and VDD2 in same potential since both are internally connected together. Due to internal connection it is only necessary to connect at least one of the two VDD pins to supply voltage.
- 2) Keep GND1 and GND2 in same potential since both are internally connected together. Due to internal connection it is only necessary to connect at least one of the two GND pins to supply ground.
- 3) Power down mode when XPD is low and operating mode when XPD is high.
- 4) Each led driver input has  $1.7\text{M}\Omega \pm 15\%$  pull-down resistor but which are in an inactive high impedance state if the XPD input is low (i.e. power down mode). This is the reason why XPD pin requires external control to achieve properly controlled operation.
- 5) Dummy pad is electrically unconnected and its only purpose is to make pad layout symmetrical.

**TYPICAL APPLICATION**

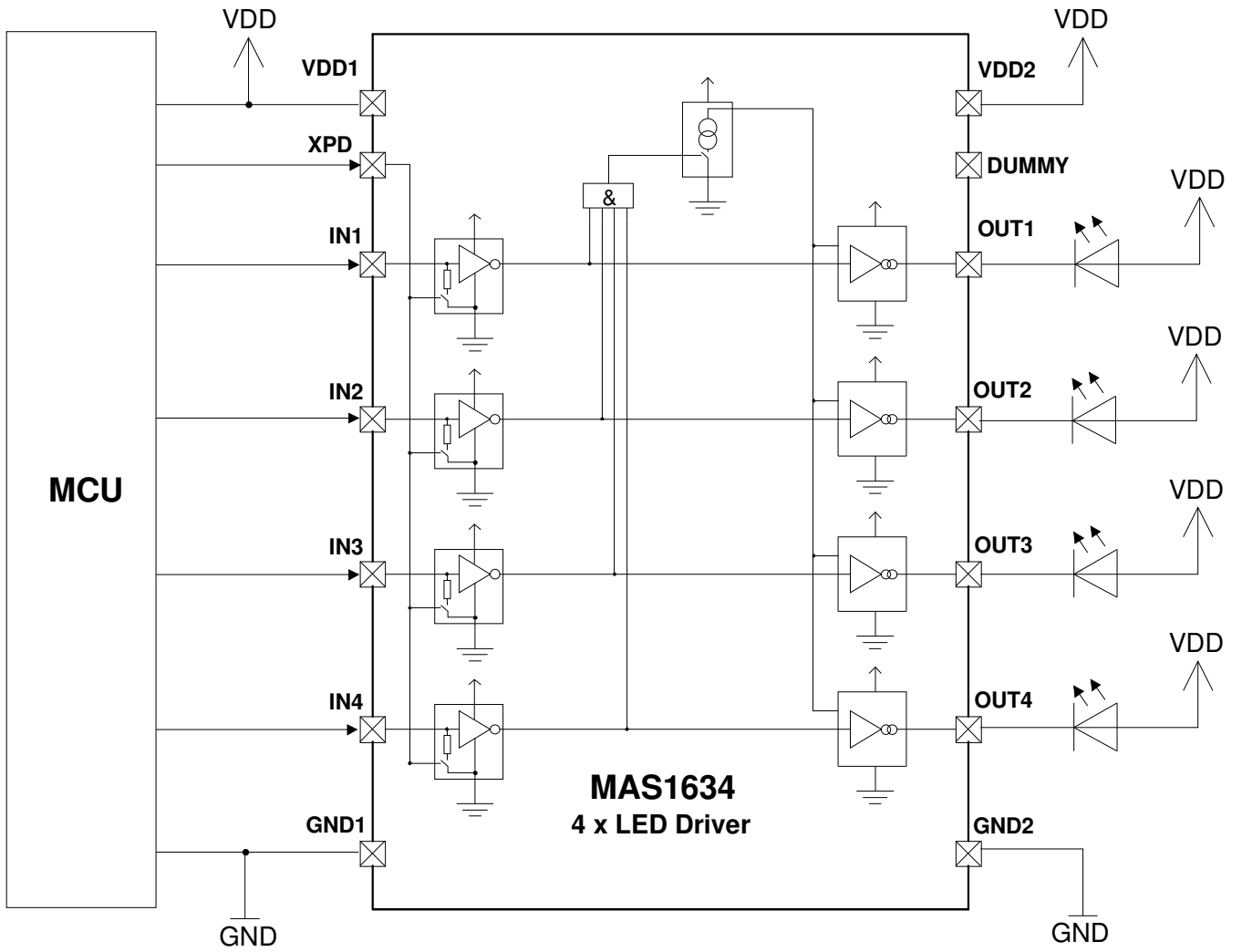

**Figure 2.** Application circuit of MAS1634 quad LED driver

## MAS1634 SAMPLES IN DIL-20 PACKAGE

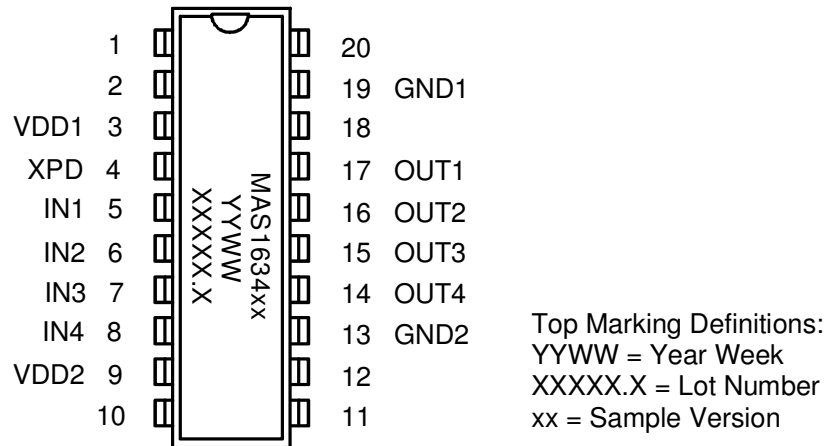

### PIN DESCRIPTION

Pin Name	Pin	Type	Function	Note
	1	NC		
	2	NC		
VDD1	3	P	Positive Power Supply	1
XPD	4	DI	Power Down Input	3
IN1	5	DI	LED Current Driver Input 1	4
IN2	6	DI	LED Current Driver Input 2	4
IN3	7	DI	LED Current Driver Input 3	4
IN4	8	DI	LED Current Driver Input 4	4
VDD2	9	P	Positive Power Supply	1
	10	NC		
	11	NC		
	12	NC		
GND2	13	G	Power Supply Ground	2
OUT4	14	AO	LED Current Driver Output 4	
OUT3	15	AO	LED Current Driver Output 3	
OUT2	16	AO	LED Current Driver Output 2	
OUT1	17	AO	LED Current Driver Output 1	
	18	NC		
GND1	19	G	Power Supply Ground	2
	20	NC		

A = Analog, D = Digital, P = Power, G = Ground, I = Input, O = Output, NC = Not Connected

#### Notes:

- 1) Keep VDD1 and VDD2 in same potential since both are internally connected together. Due to internal connection it is only necessary to connect at least one of the two VDD pins to supply voltage.
- 2) Keep GND1 and GND2 in same potential since both are internally connected together. Due to internal connection it is only necessary to connect at least one of the two GND pins to supply ground.
- 3) Power down mode when XPD is low and operating mode when XPD is high.
- 4) Each led driver input has  $1.7M\Omega \pm 15\%$  pull-down resistor but which are in an inactive high impedance state if the XPD input is low (i.e. power down mode). This is the reason why XPD pin requires external control to achieve properly controlled operation.

---

**ORDERING INFORMATION**

---

Product Code	Product	Description
MAS1634AA1WA611	Quad LED Driver IC	EWS-tested 300 µm thick MAS1634 wafer

---

**LOCAL DISTRIBUTOR**

---

---

**MICRO ANALOG SYSTEMS OY CONTACTS**

---

Micro Analog Systems Oy Kamreerintie 2, P.O. Box 51 FIN-02771 Espoo, FINLAND	Tel. +358 9 80 521 Fax +358 9 805 3213 <a href="http://www.mas-oy.com">http://www.mas-oy.com</a>
--	--

**NOTICE**

Micro Analog Systems Oy reserves the right to make changes to the products contained in this data sheet in order to improve the design or performance and to supply the best possible products. Micro Analog Systems Oy assumes no responsibility for the use of any circuits shown in this data sheet, conveys no license under any patent or other rights unless otherwise specified in this data sheet, and makes no claim that the circuits are free from patent infringement. Applications for any devices shown in this data sheet are for illustration only and Micro Analog Systems Oy makes no claim or warranty that such applications will be suitable for the use specified without further testing or modification.